

COMPAERO

CIRCULAR BACKSHELL RANGE



2025 CATALOG

CONTENTS

Introduction.....	3
Part Number Breakdowns.....	4
Component Materials.....	5
Connector Interface Codes.....	6
Material & Plating Options.....	7
Coupling Ring Options.....	8
Recommended Torque Values.....	9
Product Finder.....	10

Adapters

Series 30.....	12
Series 31.....	14
Series 35.....	16
Series 42.....	18
Series 46.....	20
Series 49.....	22
Series 55.....	24
Series 60.....	26
Series 61.....	28
Series 70.....	30
Series 73.....	32
Series 80.....	34
Series 81.....	36
Series 82.....	38

Accessories

CPTB Bands.....	40
Termination Accessories.....	42
Interface Tables.....	43
Notes.....	45

ADAPT TO ANY ENVIRONMENT...

Compaero manufacture and supply an extensive range of connector adapters to suit harsh environments across land, sea and air. Available solutions can provide both environmental and non-environmental sealing capabilities, effective EMI and RFI shielding and impressive strain relief options for almost any application.

Standard range adapters can be customized from a huge selection of options to ensure that your Compaero product is fully fit for purpose, whilst our team of experienced design engineers are on hand to work with you to provide bespoke solutions for more specific needs.



EMI/RFI SHRINK BOOT ADAPTERS
Example Shown: Series 46

Shrink boot adapters provide an economical approach to terminating overall cable and harness shields while accepting a lipped shrink boot.



ENVIRONMENTAL ADAPTERS
Example Shown: Series 60

Environmental adapters protect the wiring side of the connector from dust, dirt, moisture and fluids.



EMI/RFI ENVIRONMENTAL ADAPTERS
Example Shown: Series 80

EMI/RFI environmental adapters enclose the cable in a tightly woven metal braid comprised of wire strands, creating an effective shield which helps to prevent EMI/RFI interference.

Our part numbering system offers a straight forward and simple way to build up your perfect termination solution. Use this catalog to guide you through - interface to cable entry.

STANDARD CIRCULAR ADAPTER PART NUMBERING

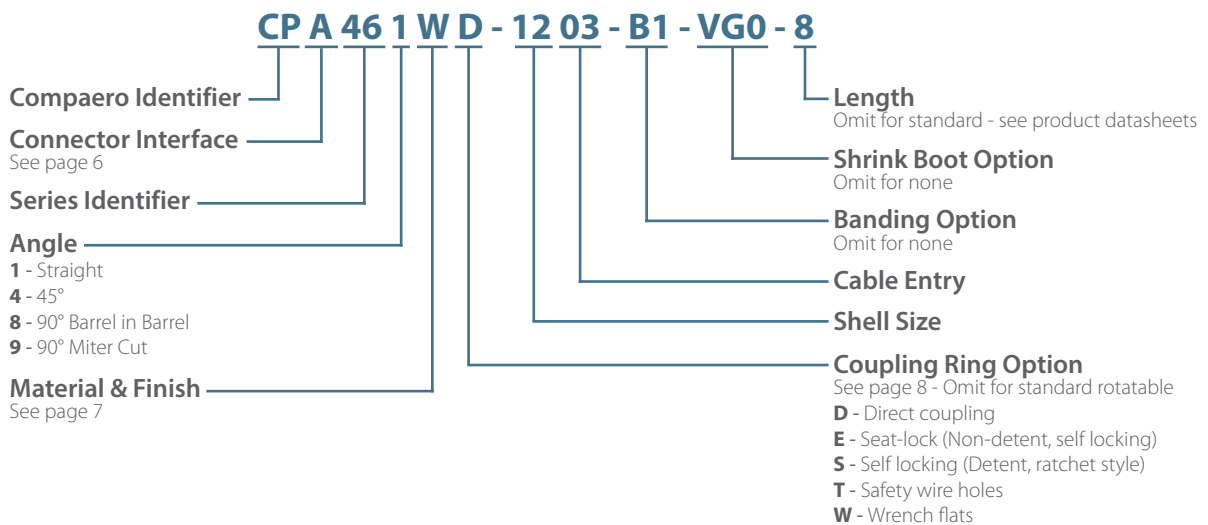

CIRCULAR BACKSHELL WITH CABLE CLAMPS PART NUMBERING

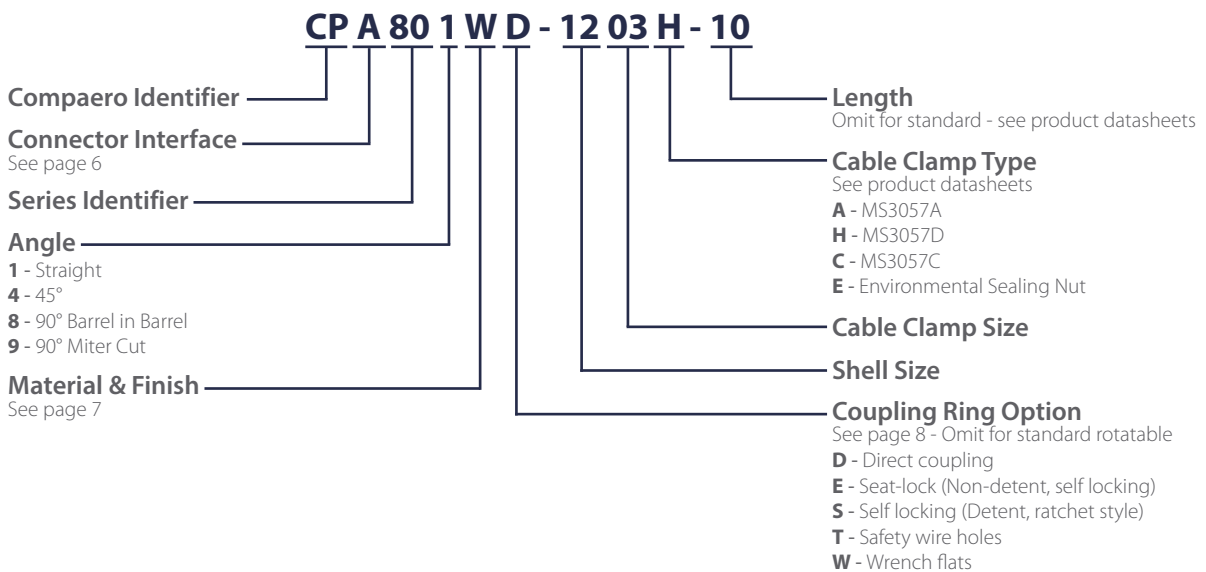

Compaero employs traceable methods when sourcing and using material. All manufacturer certifications are kept on file and are available upon request. For more information please contact the Compaero Sales Team.

COMPONENT	MATERIAL
Barrels	Aluminum 6061 or 300 Series Stainless Steel
Barrel Castings	Aluminum Alloy A380
Braid / Shield	Tinned Copper per QQB-575
Clamp Bodies	Aluminum Alloy A380, Aluminum 6061 or 300 Series Stainless Steel
Clamp Grommets, Bushings	Neoprene, Silicone or Fluorosilicone
Clamp Saddles	Aluminum Alloy A380, Aluminum 6061 or 300 Series Stainless Steel
Clamp Hardware	300 Series Stainless Steel
Coupling Rings	Aluminum 6061 or 300 Series Stainless Steel
E-Nuts	Aluminum 6061 or 300 Series Stainless Steel
Ferrules	Aluminum 6061 or 300 Series Stainless Steel
Followers	Aluminum 6061 or 300 Series Stainless Steel
O-Rings	Silicone (Red)* Fluorosilicone (Blue)*
Retaining Rings	300 Series Stainless Steel
Self Locking Clips	Non Corrosive Material

* Fluorosilicone is standard for H interface (as shown in this catalogue), all other interfaces will use silicone

Compaero offer termination solutions for virtually all known connector interfaces, the variants highlighted below are our standard lines, available on all product lines shown in this catalog.

To discuss connector interface options not shown, please contact your local sales representative, or visit www.compaero.com

CONNECTOR INTERFACE	INTERFACE CODE
EN2997, ESC10, ESC11	A
EN3645	H
MIL-DTL-26482 SERIES I SOLDER MS3110, MS3116 WITHOUT ACCESSORY TEETH	DK
MIL-DTL-26482 SERIES II MS3470, MS3471, MS3472, MS3474, MS3475, MS3476	A
MIL-DTL-38999 SERIES I & II MS27466 - 68, MS27472 - 74, MS27479 - 81, MS27484, MS27497, MS27652, MS27653, M27656	F
MIL-DTL-38999 SERIES III & IV D38999/20, /24, /26, /40, /46, /47	H
MIL-DTL-5015 SOLDER M3100, MS3101, MS3106, Amphenol - Class A (Blue Insert)	BA*
MIL-DTL-5015 SOLDER M3100, MS3101, MS3106, Bendix - Class A, E & R	BB*
MIL-DTL-5015 SOLDER M3100, MS3101, MS3106, Cannon - Class A, E & R	BC*
MIL-DTL-5015 SOLDER M3100, MS3101, MS3106, Amphenol - Class R (Resilient Insert)	BR*
MIL-DTL-5015 CRIMP MS3400, MS3401, MS3404, MS3406, MS3450, MS3451, MS3454, MS3456	A
MIL-DTL-83723 SERIES I & III M83723 /1 - /8, /13, /14, /36 - /43, /48, /49, /65 - /78, /82 - /87, /91, /92, /95, /97, /98	A
BS9522 F0017 PATT 105 AMPHENOL 62GB	VA
VG95234 / BS9522 F0032 PATT 121B ABCIR RANGE	VB

* See pages 43 & 44 for interface data

All Compaero backshells are available in a wide selection of material and plating combinations, from heavy duty marine applications to lightweight aerospace solutions, there is an option for almost any situation.

CODE	MIL SPEC CODE	MATERIAL	PLATING	PROCESS	ROHS COMPLIANT
B		Marine Bronze	Shotblast, Nonreflective	1000 Hour Salt Spray, Conductive -65 to +200°C	Yes
C	A	Aluminum	Anodize, Black	AMS-A-8625 Type II Class 2, 336 Hour Salt Spray, Non-Conductive -65 to +175°C	Yes
F	N, F	Aluminum	Electroless Nickel	AMS-C-26074 Class 4 Grade B; ASTM-B-733, SC 2, Type IV, 48 Hour Salt Spray, Conductive -65 to +200°C	Yes
G		Aluminum	Anodize, Hardcoat, Black	AMS-A-8625 Type III, Class 2, .001" thick, 336 Hour Salt Spray, Non-Conductive -65 to +200°C	Yes
KB	B	Stainless Steel	Cadmium, Black	SAE-AMS-QQ-P-416 Type II Class 3 1000 Hour Salt Spray, Conductive -65 to +175°C	No
K	S	Stainless Steel	Passivate	SAE-AMS-SAE-AMS-QQ-P-35 Type VI 1000 Hour Salt Spray, Conductive -65 to +200°C	Yes
KL		Stainless Steel	Electrodeposited Nickel	SAE-AMS-QQ-N-290 Class 1 Grade F 1000 Hour Salt Spray, Conductive -65 to +200°C	Yes
TR		Aluminum	Zinc-Nickel, Black	ASTM B841 Grade 5 over electroless nickel 500 Hour Salt Spray, Conductive -65 to +175°C	Yes
T		Aluminum	Zinc-Nickel, Black	ASTM B841 Grade 5 over electroless nickel 1000 Hour Salt Spray, Conductive -65 to +175°C	No
W	W	Aluminum	Cadmium, Olive Drab	SAE-AMS-QQ-P-416 Type II Class 2 over electroless nickel 1000 Hour Salt Spray, Conductive -65 to +175°C	No
X		Aluminum	Unplated		Yes
Y		Aluminum	Zinc-Cobalt, Olive Drab	ASTM B 840 Grade 6 Type D over electroless nickel, 350 Hour Salt Spray, Conductive -65 to +175°C	Yes
ZN		Aluminum	Zinc-Nickel, Olive Drab	ASTM B841 Grade 5 over electroless nickel 1000 Hour Salt Spray, Conductive -65 to +175°C	No
Z		Aluminum	Zinc-Cobalt, Black	ASTM B 840 Grade 6 Type D over electroless nickel 350 Hour Salt Spray, Conductive -65 to +175°C	Yes

For the full list of available options, please consult www.compaero.com
Please note that the colours shown above are for illustrative purposes only - actual finish colour may vary.

Type 2 Coupling Rings

When the selected cable entry exceeds the **MAX ENTRY** stated in the **INTERFACE TABLE**, you may choose to have a type 2 assembly. The two-piece assembly allows a large cable diameter to be maintained as close to the connector body as possible, allowing maximum continuation of screens and wire protection, whilst also providing an access point close to the connector.

To specify a type 2 assembly, place modification code -079 at the end of the part number when ordering.

Modification Code Example: CPA461W-1410-VG0-079

To receive a standard one-piece adapter, no modification code is needed.

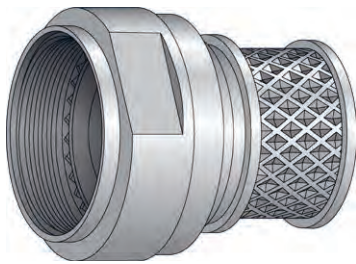
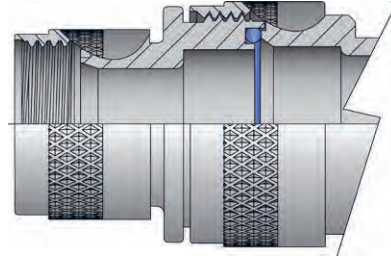

Wrench Flat Coupling Rings OPTION W

Wrench flats are an available option on most Compaero adapters and backshells, allowing for an easier way of tightening the coupling ring when working with reduced accessibility.

Direct Coupling Rings OPTION D

Available on straight adapters only.

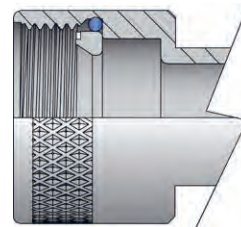

Seat-Lock Coupling Rings, Non-Detent Self-Locking OPTION E

Using a spring loaded retaining ring, Compaero Seat-Lock coupling rings are a non detent way to achieve self locking. This option ensures that the accessory teeth of the connector mate properly with the teeth on the adapter or backshell by applying constant force between the two. The Compaero Seat-Lock option is an excellent choice if an easy, economical self locking solution is required.

Safety Wire Holes OPTION T

Safety wire holes can be specified on standard rotatable coupling rings for use with safety wire after installation. Safety wire ensures the coupling ring will not un-couple during shock and/or vibration. These are common on AS85049 accessories. When this option is specified the coupling ring will have 3 equally spaced wire holes (120 degrees apart), sufficient to accommodate 0.020 inch wire.

Self-Locking Coupling Rings, Detent OPTION S

Detent style self locking features a ratcheting coupling ring using non corrosive clips located within the coupling ring. Many AS85049 specifications specify this detent style self locking coupling ring making this one of the most popular ways of achieving a self locking adapter or backshell.

The above coupling ring options are available on most Compaero backshells and adapters. Please contact the sales team for more information.

The below figures are provided to support operators already trained in the installation of heat shrinkable products and harnessing components. They identify the recommended torque values to be used when installing adapters onto circular electrical connectors, to consistently tighten adapters in a controlled manner.

For any questions or further instructions please contact us and we will be happy to assist you.

Connector Accessories onto Connector Threads

SHELL SIZE	MIL-DTL-26500 MIL-DTL-81511 MIL-DTL-26482 S1 MIL-DTL-38999 S1/S2 MIL-DTL 5015 Solder		MIL-DTL-26482 S2 MIL-DTL-28840 MIL-DTL-83723 MIL-DTL-22992 MIL-DTL-5015 Crimp MIL-DTL-38999 S3/S4	
	in - lb	Nm	in - lb	Nm
08/09	30 - 40	3.4 - 4.5	51 - 61	5.8 - 6.9
10/11	30 - 40	3.4 - 4.5	71 - 81	8.0 - 9.2
12/13	35 - 45	4.0 - 5.1	103 - 113	11.6 - 12.8
14/15	35 - 45	4.0 - 5.1	111 - 121	12.5 - 13.7
16/17	35 - 45	4.0 - 5.1	111 - 121	12.5 - 13.7
18/19	35 - 45	4.0 - 5.1	111 - 121	12.5 - 13.7
20/21	75 - 85	8.5 - 9.6	131 - 141	14.8 - 15.9
22/23	75 - 85	8.5 - 9.6	131 - 141	14.8 - 15.9
24/25	75 - 85	8.5 - 9.6	131 - 141	14.8 - 15.9
28	115 - 125	13.0 - 14.1	143 - 153	16.2 - 17.3
32	115 - 125	13.0 - 14.1	143 - 153	16.2 - 17.3
36	115 - 125	13.0 - 14.1	143 - 153	16.2 - 17.3
40	155 - 165	17.5 - 18.6	159 - 169	18.0 - 19.1
44	155 - 165	17.5 - 18.6	159 - 169	18.0 - 19.1
48	155 - 165	17.5 - 18.6	159 - 169	18.0 - 19.1

Cable Clamps onto Backshells

CLAMP-SIZE	TORQUE VALUES	
	in - lb	Nm
01	35 - 40	4.0 - 4.5
02	35 - 40	4.0 - 4.5
03	35 - 55	4.0 - 6.2
04	35 - 55	4.0 - 6.2
05	35 - 55	4.0 - 6.2
06	40 - 60	4.5 - 6.8
07	40 - 60	4.5 - 6.8
08	40 - 60	4.5 - 6.8
09	80 - 100	9.0 - 11.3
10	80 - 100	9.0 - 11.3
11	80 - 100	9.0 - 11.3
12	80 - 100	9.0 - 11.3

Cable Clamp Hardware

THREAD-SIZE	TORQUE VALUES	
	in - lb	Nm
2-56	1.5 - 2.5	0.2 - 0.3
4-40	3.5 - 4.5	0.4 - 0.5
6-32	5.0 - 7.0	0.6 - 0.8
8-32	7.0 - 9.0	0.8 - 1.0
10-32	9.0 - 11.0	1.0 - 1.2
1/4-20	11.0 - 13.0	1.2 - 1.5

Series	Termination Style	Screening Options					Strain Relief & Cable Sealing			Required Components	
		Outer (Overall) Screening	Inner (Individual) Screening	Inner and Outer Screening	Tool Free Screen Termination	Reworkable	Cable Clamp	Heat Shrink Boot Option	Compression Grommet	Boot	Band/Spring
SERIES 30 Page 12	Heat Shrink Boot	N/A	N/A	N/A	N/A	■		■		■	
SERIES 31 Page 14	Lamp Base Thread	■	■		■	■	■	■			
SERIES 35 Page 16	Shield Sock	■	■		■	■		■		■	
SERIES 43	Cable Sealing Band In A Can	■			*		■		■		■
SERIES 45	Band/Spring	■			*	■		■		■	■
SERIES 42 Page 18	Band	■				■		■		■	■
SERIES 46 Page 20	Band/Spring	■			*	■		■		■	■
SERIES 49 Page 22	Memory Ring	■						■		■	
SERIES 60 Page 26	Cable Clamp, Environmental	N/A	N/A	N/A	N/A	■	■		■		
SERIES 61 Page 28	Cable Clamp, Environmental	N/A	N/A	N/A	N/A	■	■		■		
SERIES 62	Cable Clamp, Splash-Proof	N/A	N/A	N/A	N/A	■	■		■		
SERIES 80 Page 34	Cone Clamp, Environmental	■			■	■	■		■		
SERIES 81 Page 36	Cone Clamp, Environmental	■			■	■	■		■		
SERIES 82 Page 38	Cone Clamp, Environmental		■		■	■	■		■		
SERIES 83	Cone Clamp, Environmental	■			■	■	■		■		
SERIES 84	Cone Clamp, Environmental	■			■	■	■		■		

ENVIRONMENTAL

* Tool free with constant force spring termination

Series highlighted in **yellow** are the standard series included in this catalog. For further information on the other ranges, please consult www.compaero.com or contact the sales team.

	Series	Termination Style	Screening Options					Strain Relief & Cable Sealing			Required Components	
			Outer (Overall) Screening	Inner (Individual) Screening	Inner and Outer Screening	Tool Free Screen Termination	Reworkable	Cable Clamp	Heat Shrink Boot Option	Compression Grommet	Boot	Band/Spring
ENVIRONMENTAL	SERIES 85	Cone Clamp, Splash-Proof	<input type="checkbox"/>			<input type="checkbox"/>	<input type="checkbox"/>	<input type="checkbox"/>		<input type="checkbox"/>		
	SERIES 86	Cone Clamp, Environmental	<input type="checkbox"/>	<input type="checkbox"/>	<input type="checkbox"/>	<input type="checkbox"/>	<input type="checkbox"/>	<input type="checkbox"/>		<input type="checkbox"/>		
	SERIES 87	Cone Clamp, Environmental	<input type="checkbox"/>	<input type="checkbox"/>	<input type="checkbox"/>	<input type="checkbox"/>	<input type="checkbox"/>	<input type="checkbox"/>		<input type="checkbox"/>		
	SERIES 88	Cone Clamp, Environmental	<input type="checkbox"/>	<input type="checkbox"/>		<input type="checkbox"/>	<input type="checkbox"/>	<input type="checkbox"/>		<input type="checkbox"/>		
	SERIES 89	Cone Clamp, Environmental	<input type="checkbox"/>	<input type="checkbox"/>		<input type="checkbox"/>	<input type="checkbox"/>	<input type="checkbox"/>		<input type="checkbox"/>		
NON-ENVIRONMENTAL	SERIES 40	Band/Spring	<input type="checkbox"/>			*						<input type="checkbox"/>
	SERIES 55 <small>Page 24</small>	Cable Clamp, Non-Environmental	N/A	N/A	N/A	N/A	<input type="checkbox"/>	<input type="checkbox"/>				
	SERIES 70 <small>Page 30</small>	Cone Clamp, Non-Environmental	<input type="checkbox"/>			<input type="checkbox"/>	<input type="checkbox"/>	<input type="checkbox"/>				
	SERIES 71	Cone Clamp, Non-Environmental	<input type="checkbox"/>			<input type="checkbox"/>	<input type="checkbox"/>	<input type="checkbox"/>				
	SERIES 72	Cone Clamp, Non-Environmental	<input type="checkbox"/>			<input type="checkbox"/>	<input type="checkbox"/>	<input type="checkbox"/>				
	SERIES 73 <small>Page 32</small>	Cone Clamp, Non-Environmental		<input type="checkbox"/>		<input type="checkbox"/>	<input type="checkbox"/>	<input type="checkbox"/>				
	SERIES 74	Cone Clamp, Non-Environmental	<input type="checkbox"/>	<input type="checkbox"/>		<input type="checkbox"/>	<input type="checkbox"/>	<input type="checkbox"/>				
	SERIES 75	Cone Clamp, Non-Environmental	<input type="checkbox"/>	<input type="checkbox"/>	<input type="checkbox"/>	<input type="checkbox"/>	<input type="checkbox"/>	<input type="checkbox"/>				
	SERIES 76	Cone Clamp, Non-Environmental	<input type="checkbox"/>	<input type="checkbox"/>	<input type="checkbox"/>	<input type="checkbox"/>	<input type="checkbox"/>	<input type="checkbox"/>				
	SERIES 77	Cone Clamp, Non-Environmental	<input type="checkbox"/>	<input type="checkbox"/>		<input type="checkbox"/>	<input type="checkbox"/>	<input type="checkbox"/>				

Angle 1 - Straight Rotatable Coupling

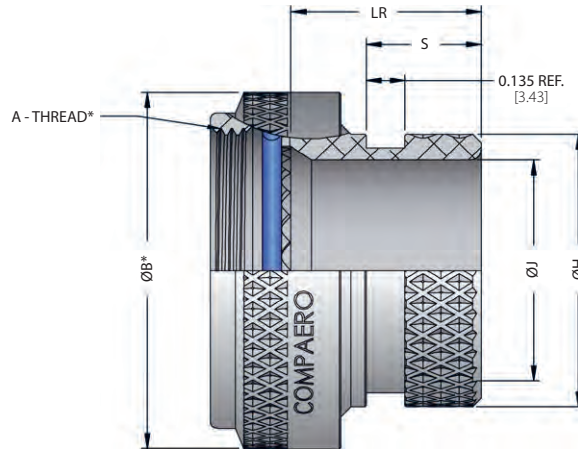

Angle 1 - Straight Direct Coupling

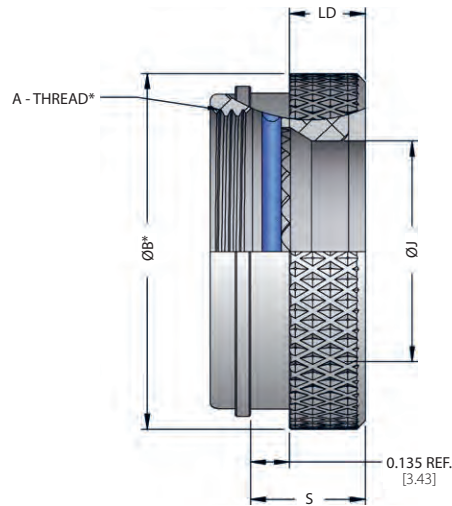

CP A 30 1 W D - 12 - VG0

- Compaero Identifier**
- Connector Interface**
See page 6 for details
- Series Identifier**
- Angle**
- Material & Finish**
See page 7 for details

- Shrink Boot Option**
Omit for no boot - See website for details
- Shell Size**
See table 1
- Coupling Ring Option**
Omit for standard rotatable
- D** - Direct coupling
- E** - Seat-lock (Non-detent, self locking)
- S** - Self locking (Detent, ratchet style)
- T** - Safety wire holes
- W** - Wrench flats
- See page 8 for more details

* Refer to interface tables in pages 43 & 44
inches [millimeters]

SERIES 30

Shrink Boot Adapter Environmental, Non-Screened

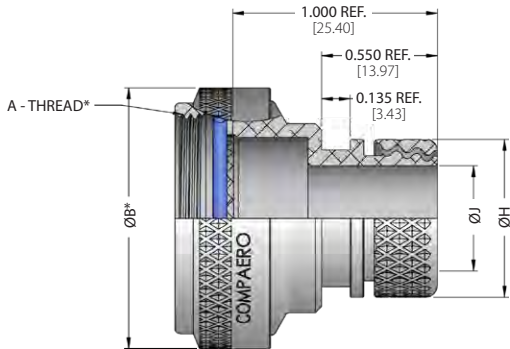

Table 1 Shell Size

SHELL SIZE	ØJ MIN		ØH MAX		S REF		LR MAX		LD MAX	
	in	mm	in	mm	in	mm	in	mm	in	mm
08/09	0.250	6.4	0.53	13.5	0.41	10.3	0.85	21.6	0.50	12.8
10/11	0.375	9.5	0.61	15.4	0.41	10.3	0.85	21.6	0.50	12.8
12/13	0.375	9.5	0.77	19.7	0.41	10.3	0.85	21.6	0.50	12.8
14/15	0.438	11.1	0.84	21.3	0.41	10.3	0.85	21.6	0.50	12.8
16/17	0.563	14.3	0.96	24.5	0.41	10.3	0.85	21.6	0.50	12.8
18/19	0.625	15.9	1.04	26.5	0.41	10.3	0.85	21.6	0.50	12.8
20/21	0.750	19.1	1.22	30.9	0.41	10.3	0.85	21.6	0.50	12.8
22/23	0.875	22.2	1.36	34.4	0.41	10.3	0.85	21.6	0.50	12.8
24/25	1.000	25.4	1.44	36.7	0.41	10.3	0.85	21.6	0.50	12.8
28/29	1.188	30.2	1.63	41.3	0.41	10.3	0.85	21.6	0.50	12.8
32/33	1.438	36.5	1.88	47.6	0.56	14.3	1.01	25.8	0.66	16.7
36	1.625	41.3	2.06	52.4	0.56	14.3	1.01	25.8	0.66	16.7
40	1.875	47.6	2.31	58.7	0.56	14.3	1.01	25.8	0.66	16.7
44	2.313	58.7	2.56	65.1	0.56	14.3	1.01	25.8	0.66	16.7
48	2.563	65.1	2.81	71.4	0.56	14.3	1.01	25.8	0.66	16.7
61	1.188	30.2	1.44	36.5	0.56	14.3	1.01	25.8	0.66	16.7

inches millimeters
Tolerance ±0.01±0.25

Angle 1 - Straight Rotatable Coupling



Clamp Option - SR Clamp

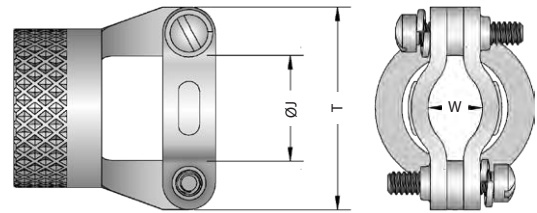

Only available on entry sizes **31-10**

Angle 4 - 45 Degree

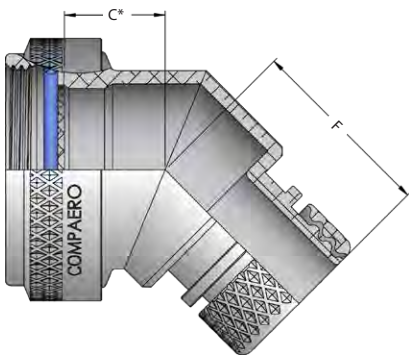

Angle 8 - 90 Degree

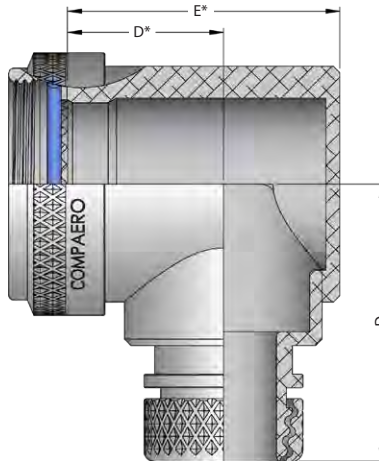

Angle 9 90 Degree Miter Cut

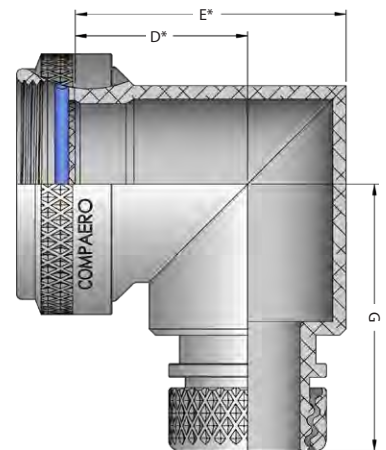

CPA 31 1 W D - 12 03 - VG0 - SR

Compaero Identifier

Connector Interface
See page 6 for details

Series Identifier

Angle

Material & Finish
See page 7 for details

Coupling Ring Option
Omit for standard rotatable

- D** - Direct coupling
- E** - Seat-lock (Non-detent, self locking)
- S** - Self locking (Detent, ratchet style)
- T** - Safety wire holes
- W** - Wrench flats
See page 8 for details

Strain Relief Option

Omit for standard E-Nut
Use SR for clamp style

Shrink Boot Option

Omit for no boot - See website for details

Cable Entry

See table 2

Shell Size

See table 1

* Refer to interface tables in pages 43 & 44
inches [millimeters]

SERIES 31

EMI/RFI Lamp Base Thread Environmental, Screened



Table 1 Shell Size

SHELL SIZE	F MAX	G MAX
	in mm	in mm
08/09	0.83 21.1	1.10 27.9
10/11	0.86 21.8	1.17 29.7
12/13	0.88 22.4	1.23 31.2
14/15	0.91 23.1	1.29 32.8
16/17	0.93 23.6	1.35 34.3
18/19	0.95 24.1	1.38 35.1
20/21	0.97 24.6	1.45 36.8
22/23	1.00 25.4	1.51 38.4
24/25	1.02 25.9	1.57 39.9
28/29	1.05 26.7	1.63 41.4
32/33	1.10 27.9	1.76 44.7
36	1.14 29.0	1.85 47.0
40	1.19 30.2	1.98 50.3
44	1.24 31.5	2.10 53.3
48	1.30 33.0	2.23 56.6
61	1.01 25.7	1.54 39.1

Table 2 Entry Size

ENTRY SIZE	ØH MAX	ØJ	T MAX	W REF
	in mm	in mm	in mm	in mm
01	0.40 10.0	0.125 3.2	n/a	n/a
31	0.46 11.6	0.188 4.8	0.68 17.3	0.12 3.0
02	0.52 13.2	0.250 6.4	0.74 18.9	0.13 3.4
32	0.58 14.8	0.313 7.9	0.81 20.5	0.20 5.0
03	0.65 16.4	0.375 9.5	0.87 22.1	0.22 5.5
33	0.71 18.0	0.438 11.1	0.93 23.6	0.24 6.0
04	0.77 19.6	0.500 12.7	0.99 25.1	0.26 6.5
34	0.83 21.1	0.563 14.3	1.06 26.8	0.38 9.7
05	0.90 22.7	0.625 15.9	1.12 28.4	0.41 10.4
35	0.96 24.3	0.688 17.5	1.19 30.1	0.45 11.5
06	1.02 25.9	0.750 19.1	1.24 31.6	0.45 11.4
36	1.08 27.5	0.813 20.6	1.30 33.1	0.55 14.0
07	1.15 29.1	0.875 22.2	1.37 34.8	0.61 15.4
37	1.21 30.7	0.938 23.8	1.44 36.5	0.66 16.8
08	1.27 32.3	1.000 25.4	1.49 37.9	0.68 17.3
38	1.33 33.8	1.063 27.0	1.56 39.5	0.74 18.8
09	1.40 35.4	1.125 28.6	1.62 41.1	0.77 19.5
10	1.52 38.6	1.250 31.8	1.74 44.3	0.92 23.4
11	1.65 41.8	1.375 34.9	n/a	n/a
12	1.77 45.0	1.500 38.1	n/a	n/a
13	1.90 48.1	1.625 41.3	n/a	n/a
14	2.02 51.3	1.750 44.5	n/a	n/a
15	2.15 54.5	1.875 47.6	n/a	n/a
16	2.27 57.7	2.000 50.8	n/a	n/a

inches millimeters
Tolerance ±0.01±0.25

Angle 1 - Straight Rotatable Coupling

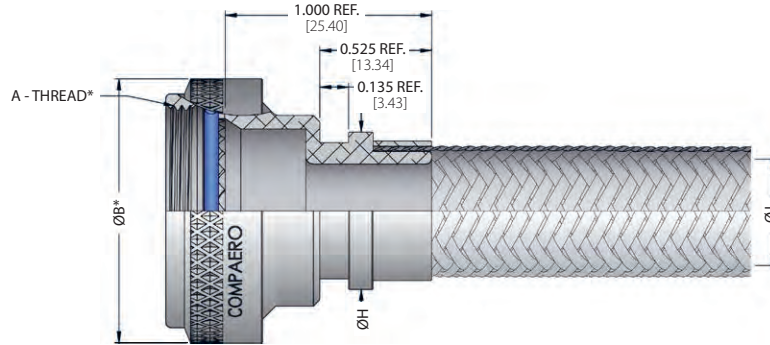

Angle 4 - 45 Degree

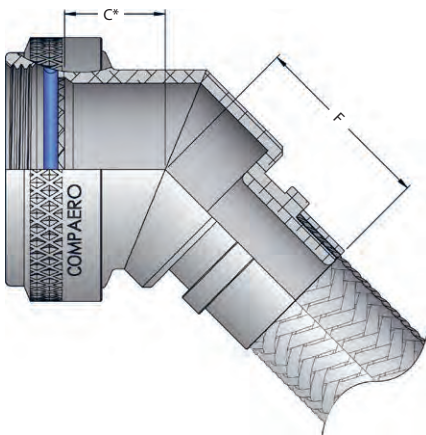

Angle 8 - 90 Degree

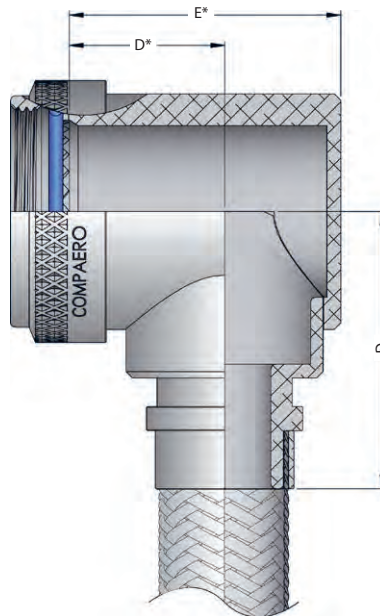

Angle 9 - 90 Degree Miter Cut

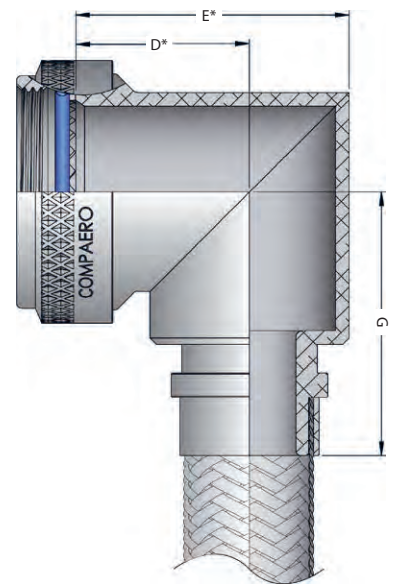

CP A 35 1 W D - 12 03 - VG0 - 6

Compaero Identifier

Connector Interface
See page 6 for details

Series Identifier

Angle

Material & Finish
See page 7 for details

Coupling Ring Option
Omit for standard rotatable

- D** - Direct coupling
 - E** - Seat-lock (Non-detent, self locking)
 - S** - Self locking (Detent, ratchet style)
 - T** - Safety wire holes
 - W** - Wrench flats
- See page 8 for details

Shield Length

Supplied in 1 Inch increments
-6 (6") as standard

Shrink Boot Option

Omit for no boot - See website for details

Cable Entry

See table 2

Shell Size

See table 1

* Refer to interface tables in pages 43 & 44
inches [millimeters]

SERIES 35

Shield Sock Shrink Boot Adapter Environmental, Screened



Table 1 Shell Size

SHELL SIZE	F MAX	G MAX
	in mm	in mm
08/09	0.81 20.6	1.10 27.9
10/11	0.83 21.1	1.17 29.7
12/13	0.86 21.8	1.23 31.2
14/15	0.88 22.4	1.29 32.8
16/17	0.91 23.1	1.35 34.3
18/19	0.92 23.4	1.38 35.1
20/21	0.95 24.1	1.45 36.8
22/23	0.97 24.6	1.51 38.4
24/25	1.00 25.4	1.57 39.9
28/29	1.03 26.2	1.63 41.4
32/33	1.08 27.4	1.76 44.7
36	1.12 28.4	1.85 47.0
40	1.17 29.7	1.98 50.3
44	1.22 31.0	2.10 53.3
48	1.27 32.3	2.23 56.6
61	0.99 25.1	1.54 39.1

Table 2 Entry Size

ENTRY	ØH MAX	ØJ
	in mm	in mm
01	0.445 11.3	0.125 3.2
31	0.508 12.9	0.188 4.8
02	0.570 14.5	0.250 6.4
32	0.633 16.1	0.313 7.9
03	0.695 17.7	0.375 9.5
33	0.758 19.2	0.438 11.1
04	0.820 20.8	0.500 12.7
34	0.883 22.4	0.563 14.3
05	0.945 24.0	0.625 15.9
35	1.008 25.6	0.688 17.5
06	1.070 27.2	0.750 19.1
36	1.133 28.8	0.813 20.6
07	1.195 30.4	0.875 22.2
37	1.258 31.9	0.938 23.8
08	1.320 33.5	1.000 25.4
38	1.383 35.1	1.063 27.0
09	1.445 36.7	1.125 28.6
10	1.570 39.9	1.250 31.8
11	1.695 43.1	1.375 34.9
12	1.820 46.2	1.500 38.1
13	1.945 49.4	1.625 41.3
14	2.070 52.6	1.750 44.5
15	2.195 55.8	1.875 47.6
16	2.320 58.9	2.000 50.8

inches millimeters
Tolerance ±0.01±0.25

Angle 1 - Straight

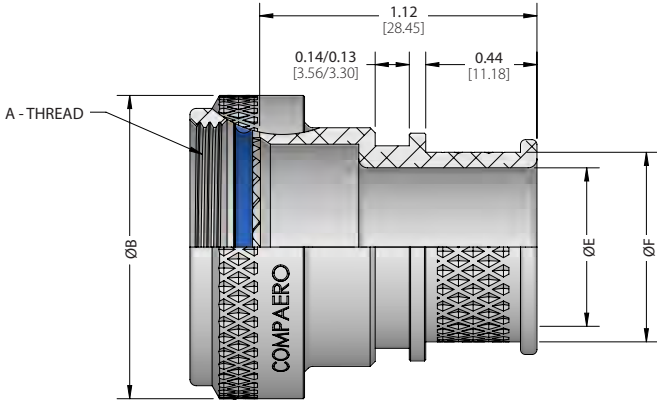

Angle 4 - 45 Degree

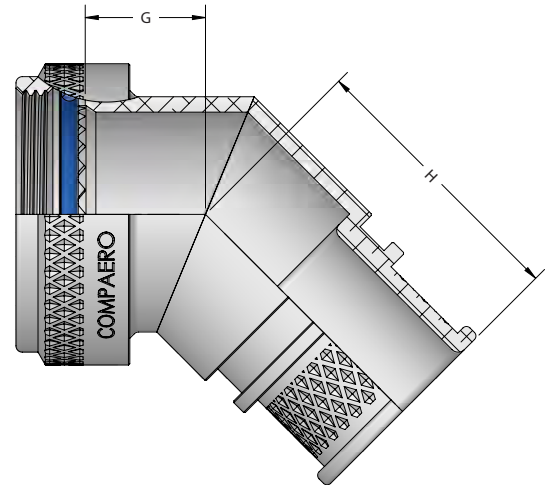

Angle 8 - 90 Degree

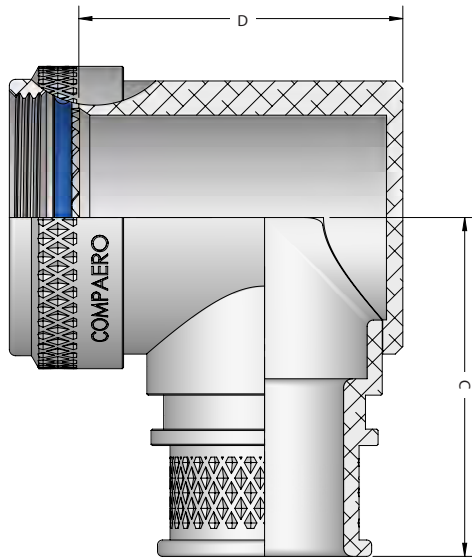

CP H 42 1 W S - 11 03 - B1 - VG0

Compaero Identifier

Connector Interface
See Page 6 for details

Series Identifier

Angle

Material & Finish
See Page 7 for details

Coupling Ring Option

Omit for standard rotatable
E - Seat-lock (Non-detent, self locking)
S - Self locking (Detent, ratchet style)

Shrink Boot Option

Omit for no Boot - See website for details

Banding Option

Omit for none
B - Stamped Buckle Band (Flat)
B1 - Stamped Buckle Band (Pre-Coiled)
M - Stamped Buckle Mini Band (Flat)
M1 - Stamped Buckle Mini Band (Pre-Coiled)
See Page 40 for details

Cable Entry

See table 2

Shell Size

See table 1 corresponding to each interface

Table 1 Shell Size - F INTERFACE

SHELL SIZE	A THREAD CLASS 2B	ØB (REF.)		C MAX.		D MAX.		G MAX.		H MAX.		MAX. ENTRY *
		in	mm	in	mm	in	mm	in	mm	in	mm	
08	7 / 16 - 28 UNEF	0.66	16.76	1.29	32.77	0.87	22.10	0.50	12.70	1.02	25.91	02
10	9 / 16 - 24 UNEF	0.78	19.81	1.35	34.29	1.00	25.40	0.52	13.21	1.04	26.42	03
12	11 / 16 - 24 UNEF	0.90	22.86	1.42	36.07	1.12	28.45	0.55	13.97	1.07	27.18	04
14	13 / 16 - 20 UNEF	1.10	27.94	1.48	37.59	1.25	31.75	0.58	14.73	1.10	27.94	05
16	15 / 16 - 20 UNEF	1.23	31.24	1.54	39.12	1.37	34.80	0.60	15.24	1.12	28.45	06
18	1 - 1 / 16 - 18 UNEF	1.36	34.54	1.57	39.88	1.50	38.10	0.61	15.49	1.13	28.70	07
20	1 - 3 / 16 - 18 UNEF	1.48	37.59	1.63	41.40	1.62	41.15	0.66	16.76	1.16	29.46	08
22	1 - 5 / 16 - 18 UNEF	1.61	40.89	1.70	43.18	1.75	44.45	0.68	17.27	1.19	30.23	09
24	1 - 7 / 16 - 18 UNEF	1.67	42.42	1.76	44.70	1.87	47.50	0.68	17.27	1.21	30.73	10



Table 1 Shell Size - A INTERFACE

SHELL SIZE	A THREAD CLASS 2B	ØB MAX.		C MAX.	D MAX.	G MAX.	H MAX.	MAX. ENTRY *				
		in	mm									
03	9/16-24 UNEF	0.770	19.56	1.06	26.92	0.96	24.38	0.639	16.23	1.078	27.38	02
08	1/2-20 UNF	0.719	18.26	1.06	26.92	0.96	24.38	0.639	16.23	1.078	27.38	02
10	5/8-24 UNEF	0.844	21.44	1.12	28.45	1.07	27.18	0.664	16.87	1.108	28.14	03
12	3/4-20 UNEF	0.969	24.61	1.19	30.23	1.20	30.48	0.688	17.48	1.128	28.65	04
14	7/8-20 UNEF	1.094	27.79	1.23	31.24	1.28	32.51	0.705	17.91	1.158	29.41	04
16	1 - 20 UNEF	1.219	30.96	1.29	32.77	1.40	35.56	0.732	18.59	1.178	29.92	05
18	1 - 1/16 - 18 UNEF	1.281	32.54	1.33	33.78	1.48	37.59	0.748	19.00	1.188	30.18	06
20	1 - 3/16-18 UNEF	1.406	35.71	1.39	35.31	1.60	40.64	0.773	19.63	1.208	30.68	07
22	1 - 5/16 - 18 UNEF	1.531	38.89	1.46	37.08	1.73	43.94	0.800	20.32	1.248	31.70	08
24	1 - 7/16-18 UNEF	1.656	42.06	1.51	38.35	1.84	46.74	0.823	20.90	1.278	32.46	09
28	1 - 3/4-18 UNS	1.970	50.04	1.63	41.40	2.07	52.58	1.041	26.44	1.448	36.78	11
32	2-18 UNS	2.220	56.39	1.75	44.45	2.20	55.88	1.092	27.74	1.488	37.80	12
36	2 - 1/4-16 UN	2.470	62.74	1.85	46.99	2.45	62.23	1.136	28.85	1.538	39.07	14
40	2 - 1/2-16 UN	2.720	69.09	1.97	50.04	2.70	68.58	1.182	30.02	1.583	40.21	16
44	2 - 3/4-16 UN	2.970	75.44	2.10	53.34	2.95	74.93	1.233	31.32	1.635	41.53	18
48	3-16 UN	3.220	81.79	2.22	56.39	3.20	81.28	1.285	32.64	1.687	42.85	20
61	1 - 1/2-18 UNEF	1.670	42.42	1.53	38.86	1.84	46.74	1.000	25.40	1.403	35.64	09

Table 1 Shell Size - H INTERFACE

SHELL SIZE	A THREAD	ØB MAX.		C MAX.	D MAX.	G MAX.	H MAX.	MAX. ENTRY *				
		in	mm									
09	M12 x 1.0 - 6H	0.80	20.32	1.08	27.43	0.96	24.38	0.42	10.67	1.02	25.91	02
11	M15 x 1.0 - 6H	0.88	22.35	1.15	29.21	1.09	27.69	0.44	11.18	1.04	26.42	03
13	M18 x 1.0 - 6H	1.03	26.16	1.20	30.48	1.21	30.73	0.49	12.45	1.07	27.18	04
15	M22 x 1.0 - 6H	1.18	29.97	1.27	32.26	1.39	35.31	0.51	12.95	1.10	27.94	05
17	M25 x 1.0 - 6H	1.28	32.51	1.33	33.78	1.52	38.61	0.55	13.97	1.12	28.45	06
19	M28 x 1.0 - 6H	1.43	36.32	1.37	34.80	1.55	39.37	0.57	14.48	1.13	28.70	07
21	M31 x 1.0 - 6H	1.53	38.86	1.44	36.58	1.67	42.42	0.60	15.24	1.16	29.46	08
23	M34 x 1.0 - 6H	1.68	42.67	1.50	38.10	1.80	45.72	0.63	16.00	1.19	30.23	09
25	M37 x 1.0 - 6H	1.78	45.21	1.56	39.62	1.92	48.77	0.65	16.51	1.21	30.73	09

Table 2 Entry Size

ENTRY SIZE	ØE		ØF	
	in	mm	in	mm
01	0.125	3.18	0.250	6.35
31	0.188	4.78	0.313	7.95
02	0.250	6.35	0.375	9.53
32	0.313	7.95	0.438	11.13
03	0.375	9.53	0.500	12.70
33	0.438	11.13	0.563	14.30
04	0.500	12.70	0.625	15.88
34	0.563	14.30	0.688	17.48
05	0.625	15.88	0.750	19.05
35	0.688	17.48	0.813	20.65
06	0.750	19.05	0.875	22.23
36	0.813	20.65	0.938	23.83
07	0.875	22.23	1.000	25.40
37	0.938	23.83	1.063	27.00
08	1.000	25.40	1.125	28.58
38	1.063	27.00	1.188	30.18
09	1.125	28.58	1.250	31.75
10	1.250	31.75	1.375	34.93
11	1.375	34.93	1.500	38.10
12	1.500	38.10	1.625	41.28
13	1.625	41.28	1.750	44.45
14	1.750	44.45	1.875	47.63
15	1.875	47.63	2.000	50.80
16	2.000	50.80	2.125	53.98
18	2.250	57.15	2.375	60.33
20	2.500	63.50	2.625	66.68

inches millimeters

Tolerances:
 Decimals : .XX ± 0.03 ±0.76
 Decimals : .XXX ± 0.015 ±0.38

* If Max. Entry is exceeded, Dimension "D" will not apply.

* If the self-locking option (E or S) is selected, then dimensions "G", "H", "D", "C", and "ØB" does not apply. Contact factory for more information.

SERIES 46

EMI/RFI Shrink Boot Bandstrap Adapter Environmental, Screened



Angle 1 - Straight Rotatable Coupling

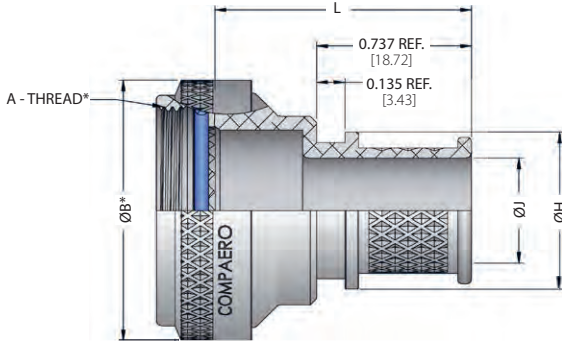

Angle 4 - 45 Degree

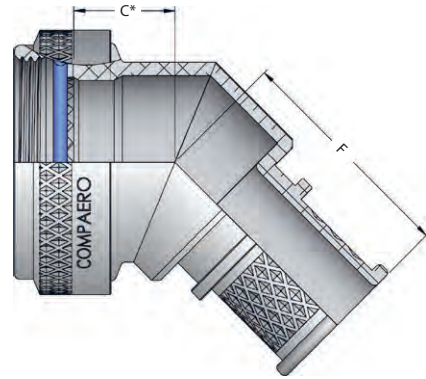

Angle 8 - 90 Degree

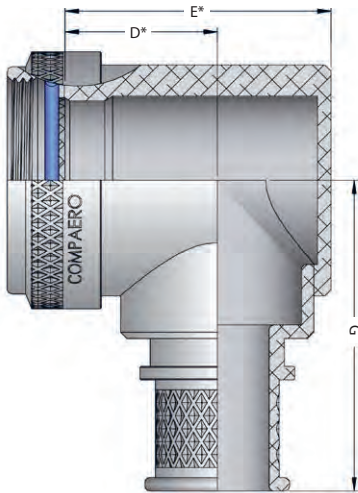

Angle 9 - 90 Degree Miter Cut

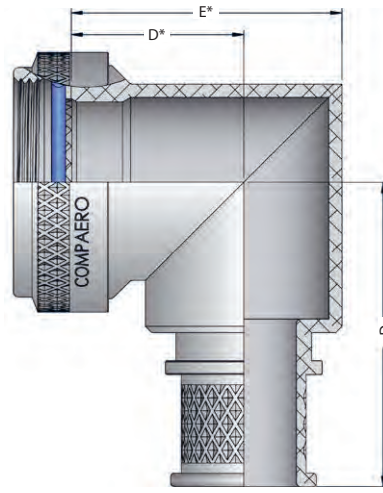

CP A 46 1 W D - 12 03 - B1 - VG0 - 8

Compaero Identifier

Connector Interface

See page 6 for details

Series Identifier

Angle

Material & Finish

See page 7 for details

Coupling Ring Option

Omit for standard rotatable

D - Direct coupling

E - Seat-lock (Non-detent, self locking)

S - Self locking (Detent, ratchet style)

T - Safety wire holes

W - Wrench flats

See page 8 for details

Length

See dimension L - In 0.25 Inch increments

Omit for 1.25" (Standard) & angled parts

Shrink Boot Option

Omit for no boot - See website for details

Banding Option

Omit for none

S - Constant Force Spring Band

B - Stamped Buckle Band (flat)

B1 - Stamped Buckle Band (pre-coiled)

M - Stamped Buckle Mini Band (flat)

M1 - Stamped Buckle Mini Band (pre-coiled)

See page 40 for details

Cable Entry

See table 2

Shell Size

See table 1

* Refer to interface tables in pages 43 & 44

inches [millimeters]

SERIES 46

EMI/RFI Shrink Boot Bandstrap Adapter Environmental, Screened



Table 1 Shell Size

SHELL SIZE	F MAX	G MAX
	in mm	in mm
08/09	1.02 25.9	1.29 32.8
10/11	1.04 26.4	1.35 34.3
12/13	1.07 27.2	1.42 36.1
14/15	1.10 27.9	1.48 37.6
16/17	1.12 28.4	1.54 39.1
18/19	1.13 28.7	1.57 39.9
20/21	1.16 29.5	1.63 41.4
22/23	1.19 30.2	1.70 43.2
24/25	1.21 30.7	1.76 44.7
28/29	1.24 31.5	1.82 46.2
32/33	1.29 32.8	1.95 49.5
36	1.33 33.8	2.04 51.8
40	1.38 35.1	2.17 55.1
44	1.43 36.3	2.29 58.2
48	1.48 37.6	2.42 61.5
61	1.20 30.5	1.73 43.9

Table 2 Entry Size

ENTRY SIZE	ØH MAX	ØJ
	in mm	in mm
01	0.392 10.0	0.125 3.2
31	0.455 11.5	0.188 4.8
02	0.517 13.1	0.250 6.4
32	0.580 14.7	0.313 7.9
03	0.642 16.3	0.375 9.5
33	0.705 17.9	0.438 11.1
04	0.767 19.5	0.500 12.7
34	0.830 21.1	0.563 14.3
05	0.892 22.7	0.625 15.9
35	0.955 24.2	0.688 17.5
06	1.017 25.8	0.750 19.1
36	1.080 27.4	0.813 20.6
07	1.142 29.0	0.875 22.2
37	1.205 30.6	0.938 23.8
08	1.267 32.2	1.000 25.4
38	1.330 33.8	1.063 27.0
09	1.392 35.4	1.125 28.6
10	1.517 38.5	1.250 31.8
11	1.642 41.7	1.375 34.9
12	1.767 44.9	1.500 38.1
13	1.892 48.1	1.625 41.3
14	2.017 51.2	1.750 44.5
15	2.142 54.4	1.875 47.6
16	2.267 57.6	2.000 50.8

inches millimeters
Tolerance ±0.01±0.25

Angle 1 - Straight Rotatable Coupling

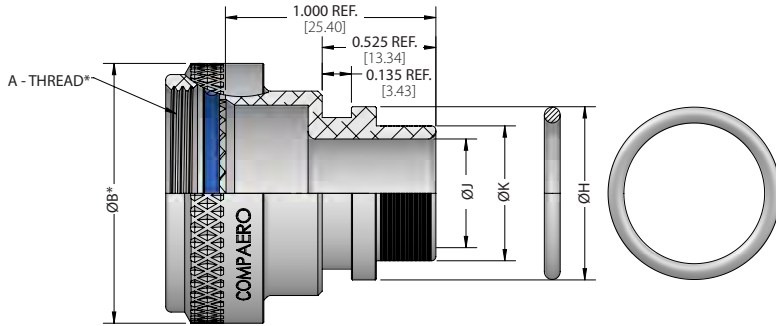

Angle 4 - 45 Degree

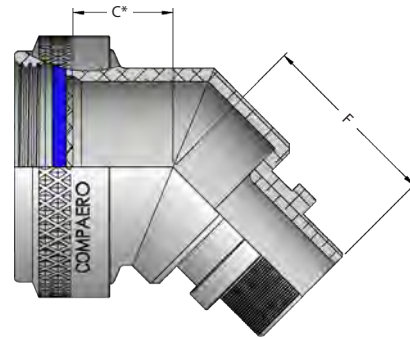

Angle 8 - 90 Degree

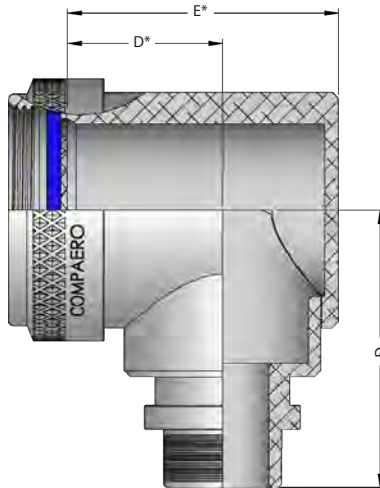

Angle 9 90 Degree Miter Cut

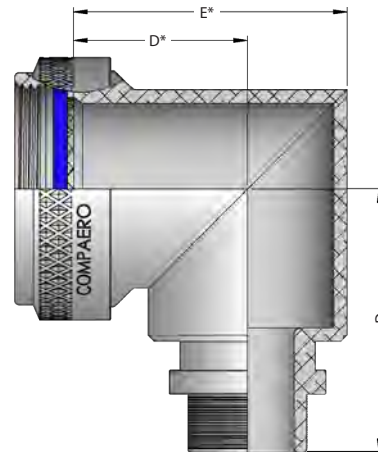

CP A 49 1 W D - 12 03 - AI - VG0

Compaero Identifier

Connector Interface

See page 6 for details

Series Identifier

Angle

Material & Finish

See page 7 for details

Coupling Ring Option

Omit for standard rotatable

D - Direct coupling

E - Seat-lock (Non-detent, self locking)

S - Self locking (Detent, ratchet style)

T - Safety wire holes

W - Wrench flats

See page 8 for details

Shrink Boot Option

Omit for no boot - See website for details

Memory Ring

Omit for none - See page 42 for details

AI - Ring for single AWG braid

BI - Ring for double 36 AWG braid

Cable Entry

See table 2

Shell Size

See table 1

* Refer to interface tables in pages 43 & 44
inches [millimeters]

SERIES 49

EMI/RFI Memory Ring Shrink Boot Adapter Environmental, Screened



Table 1 Shell Size

SHELL SIZE	F MAX	G MAX
	in mm	in mm
08/09	0.81 20.6	1.10 27.9
10/11	0.83 21.1	1.17 29.7
12/13	0.86 21.8	1.23 31.2
14/15	0.88 22.4	1.29 32.8
16/17	0.91 23.1	1.35 34.3
18/19	0.92 23.4	1.38 35.1
20/21	0.95 24.1	1.45 36.8
22/23	0.97 24.6	1.51 38.4
24/25	1.00 25.4	1.57 39.9
28/29	1.03 26.2	1.63 41.4
32/33	1.08 27.4	1.76 44.7
36	1.12 28.4	1.85 47.0
40	1.17 29.7	1.98 50.3
44	1.22 31.0	2.10 53.3
48	1.27 32.3	2.23 56.6
61	0.99 25.1	1.54 39.1

Table 2 Entry Size

ENTRY	ØH MAX	ØJ	ØK
	in mm	in mm	in mm
02	0.570 14.5	0.250 6.4	0.373 9.5
32	0.633 16.1	0.313 7.9	0.435 11.1
03	0.695 17.7	0.375 9.5	0.498 12.7
33	0.758 19.2	0.438 11.1	0.560 14.3
04	0.820 20.8	0.500 12.7	0.623 15.9
05	0.945 24.0	0.625 15.9	0.747 19.0
06	1.070 27.2	0.750 19.1	0.872 22.2
07	1.195 30.4	0.875 22.2	0.997 25.4
08	1.320 33.5	1.000 25.4	1.122 28.5
09	1.445 36.7	1.125 28.6	1.247 31.7
10	1.570 39.9	1.250 31.8	1.372 34.9
11	1.695 43.1	1.375 34.9	1.495 38.0
12	1.820 46.2	1.500 38.1	1.620 41.2

inches millimeters
Tolerance ±0.01±0.25

SERIES 55

Cable Clamp Adapter Non-Environmental, Non-Screened

COMPAERO

Angle 1 - Straight Rotatable Coupling, Type A Clamp

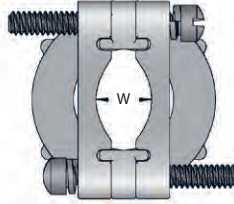
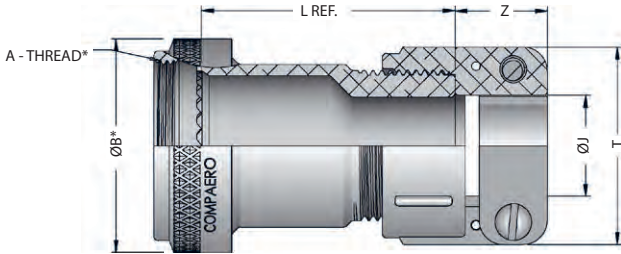

Clamp Option - Type H Clamp

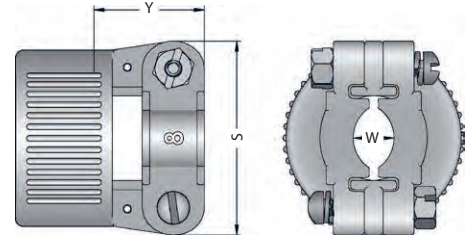

Angle 4 - 45 Degree

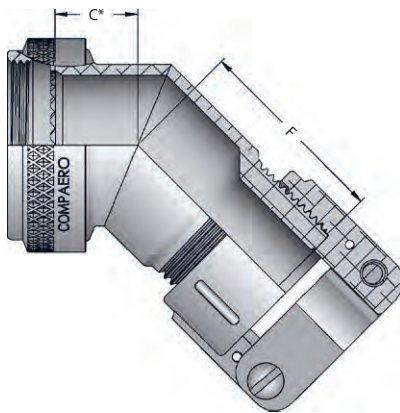

Angle 8 - 90 Degree

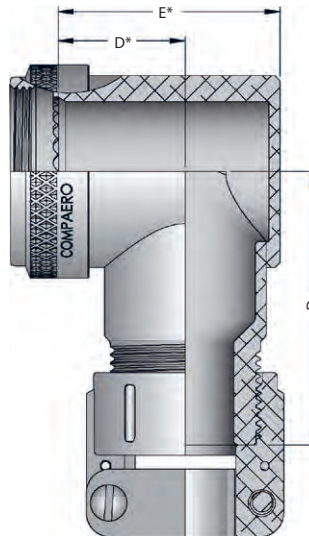

Angle 9 - 90 Degree Miter Cut

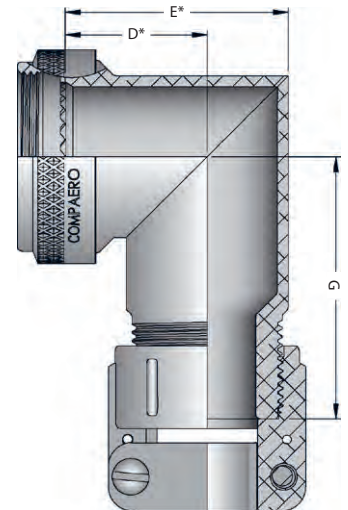

CP A 55 1 W D - 12 03 H - 10

Compaero Identifier

Connector Interface

See page 6 for details

Series Identifier

Angle

Material & Finish

See page 7 for details

Coupling Ring Option

Omit for standard rotatable

D - Direct coupling

E - Seat-lock (Non-detent, self locking)

S - Self locking (Detent, ratchet style)

T - Safety wire holes

W - Wrench flats

See page 8 for details

Length Option

Omit for 1.50" (Standard) & angled parts
0.25" Increments (10 = 2.50")

Cable Clamp Type

A - MS3057A (shown in drawings)

H - MS3057D

Cable Clamp Size

See table 2&3

Shell Size

See table 1

* Refer to interface tables in pages 43 & 44
inches [millimeters]

SERIES 55

Cable Clamp Adapter Non-Environmental, Non-Screened



Table 1 Shell Size

SHELL SIZE	F MAX	G MAX
	in mm	in mm
08/09	0.88 22.4	1.17 29.7
10/11	0.91 23.1	1.23 31.2
12/13	0.93 23.6	1.29 32.8
14/15	0.96 24.4	1.35 34.3
16/17	0.98 24.9	1.42 36.1
18/19	1.00 25.4	1.45 36.8
20/21	1.02 25.9	1.51 38.4
22/23	1.05 26.7	1.57 39.9
24/25	1.07 27.2	1.63 41.4
28/29	1.10 27.9	1.70 43.2
32/33	1.15 29.2	1.82 46.2
36	1.19 30.2	1.92 48.8
40	1.24 31.5	2.04 51.8
44	1.29 32.8	2.17 55.1
48	1.35 34.3	2.29 58.2
61	1.06 26.9	1.60 40.6

Table 2 Type A Clamp

ENTRY CODE	CLAMP REF	ØJ	T MAX	W REF	Z MAX
		in mm	in mm	in mm	in mm
01	CP3057-3A	0.250 6.4	0.84 21.4	0.16 4.0	0.45 11.5
02	CP3057-4A	0.312 7.9	0.91 23.0	0.19 4.8	0.45 11.5
03	CP3057-6A	0.438 11.1	1.09 27.8	0.28 7.1	0.52 13.1
04	CP3057-8A	0.563 14.3	1.19 30.1	0.34 8.7	0.58 14.7
05	CP3057-10A	0.625 15.9	1.28 32.5	0.38 9.5	0.58 14.7
06	CP3057-12A	0.750 19.1	1.50 38.1	0.44 11.1	0.58 14.7
07	CP3057-16A	0.938 23.8	1.72 43.7	0.56 14.3	0.67 17.1
08	CP3057-20A	1.250 31.8	2.06 52.4	0.75 19.1	0.67 17.1
09	CP3057-24A	1.375 34.9	2.31 58.7	0.78 19.8	0.67 17.1
10	CP3057-28A	1.625 41.3	2.72 69.1	0.97 24.6	1.20 30.6
11	CP3057-32A	1.875 47.6	2.97 75.4	1.13 28.6	1.20 30.6

Table 3 Type H Clamp

ENTRY CODE	CLAMP REF	ØJ	S MAX	W REF	Y MAX
		in mm	in mm	in mm	in mm
02	CP3057-4D	0.313 7.9	0.96 24.3	0.17 4.2	0.78 19.8
03	CP3057-6D	0.438 11.1	1.15 29.1	0.29 7.3	0.78 19.8
04	CP3057-8D	0.563 14.3	1.33 33.8	0.34 8.7	0.78 19.8
05	CP3057-10D	0.625 15.9	1.33 33.8	0.37 9.5	0.78 19.8
06	CP3057-12D	0.750 19.1	1.55 39.4	0.52 13.2	0.81 20.6
07	CP3057-16D	0.938 23.8	1.77 45.0	0.64 16.3	0.91 23.0
08	CP3057-20D	1.250 31.8	2.11 53.7	0.86 21.7	1.09 27.7
09	CP3057-24D	1.375 34.9	2.36 60.0	0.99 25.1	1.12 28.5
10	CP3057-28D	1.625 41.3	2.77 70.4	1.26 32.1	1.40 35.5
11	CP3057-32D	1.875 47.6	3.02 76.7	1.42 36.0	1.40 35.5

inches millimeters
Tolerance ±0.01±0.25

SERIES 60

Submersible Cable Clamp Adapter Environmental, Non-Screened

COMPAERO

Angle 1 - Straight Rotatable Coupling, Type A Clamp

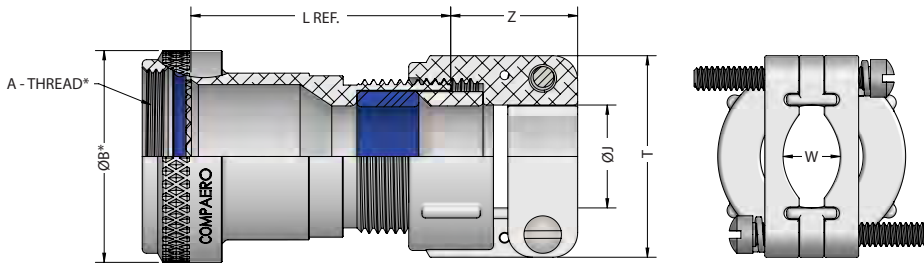

Clamp Option - Type H Clamp

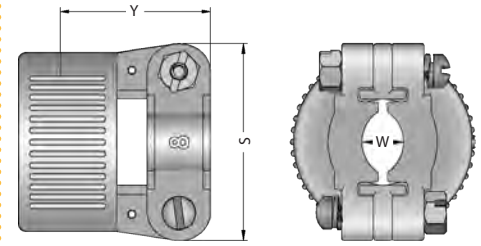

Angle 4 - 45 Degree

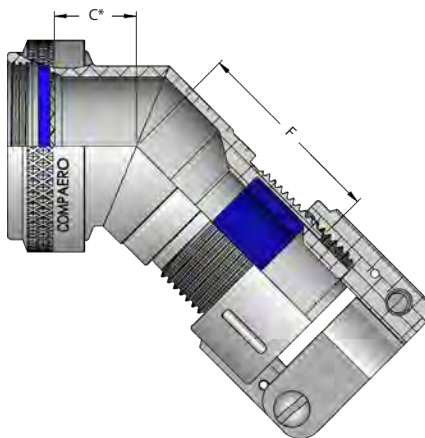

Angle 8 - 90 Degree

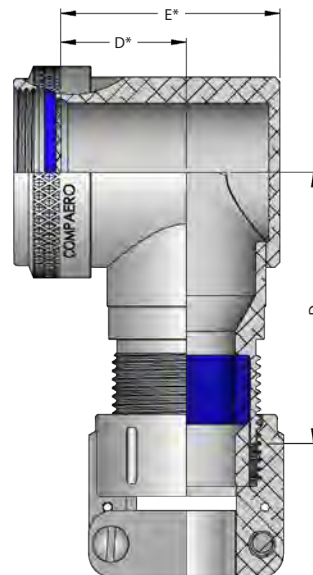

Angle 9 90 Degree Miter Cut

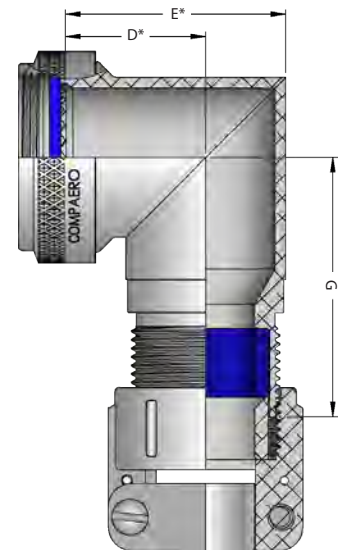

CP A 60 1 W D - 12 03 H - 10

Compaero Identifier

Connector Interface

See page 6 for details

Series Identifier

Angle

Material & Finish

See page 7 for details

Coupling Ring Option

Omit for standard rotatable

D - Direct coupling

E - Seat-lock (Non-detent, self locking)

S - Self locking (Detent, ratchet style)

T - Safety wire holes

W - Wrench flats

See page 8 for details

Length Option

Omit for 1.50" (Standard) & angled parts
0.25" Increments (10 = 2.50")

Cable Clamp Type

A - MS3057A (shown in drawings)

H - MS3057D

Cable Clamp Size

See table 2 & 3

Shell Size

See table 1

* Refer to interface tables in pages 43 & 44
inches [millimeters]

SERIES 60

Submersible Cable Clamp Adapter Environmental, Non-Screened



Table 1 Shell Size

SHELL SIZE	F MAX	G MAX
	in mm	in mm
08/09	1.08 27.4	1.35 34.3
10/11	1.11 28.2	1.42 36.1
12/13	1.13 28.7	1.48 37.6
14/15	1.16 29.5	1.54 39.1
16/17	1.19 30.2	1.60 40.6
18/19	1.20 30.5	1.63 41.4
20/21	1.22 31.0	1.70 43.2
22/23	1.25 31.8	1.76 44.7
24/25	1.28 32.5	1.82 46.2
28/29	1.30 33.0	1.88 47.8
32/33	1.35 34.3	2.01 51.1
36	1.39 35.3	2.10 53.3
40	1.44 36.6	2.23 56.6
44	1.50 38.1	2.35 59.7
48	1.55 39.4	2.48 63.0
61	1.26 32.0	1.79 45.5

Table 2 Type A Clamp

ENTRY CODE	CLAMP REF	ØJ	T MAX	W REF	Z MAX
		in mm	in mm	in mm	in mm
01	CP3057-3A	0.250 6.4	0.84 21.4	0.16 4.0	0.80 20.2
02	CP3057-4A	0.312 7.9	0.91 23.0	0.19 4.8	0.80 20.2
03	CP3057-6A	0.438 11.1	1.09 27.8	0.28 7.1	0.86 21.8
04	CP3057-8A	0.563 14.3	1.19 30.1	0.34 8.7	0.92 23.4
05	CP3057-10A	0.625 15.9	1.28 32.5	0.38 9.5	0.92 23.4
06	CP3057-12A	0.750 19.1	1.50 38.1	0.44 11.1	0.92 23.4
07	CP3057-16A	0.938 23.8	1.72 43.7	0.56 14.3	1.02 25.8
08	CP3057-20A	1.250 31.8	2.06 52.4	0.75 19.1	1.02 25.8
09	CP3057-24A	1.375 34.9	2.31 58.7	0.78 19.8	1.02 25.8
10	CP3057-28A	1.625 41.3	2.72 69.1	0.97 24.6	1.55 39.3
11	CP3057-32A	1.875 47.6	2.97 75.4	1.13 28.6	1.55 39.3

Table 3 Type H Clamp

ENTRY CODE	CLAMP REF	ØJ	S MAX	W REF	Y MAX
		in mm	in mm	in mm	in mm
02	CP3057-4D	0.313 7.9	0.96 24.3	0.17 4.2	1.12 28.5
03	CP3057-6D	0.438 11.1	1.15 29.1	0.29 7.3	1.12 28.5
04	CP3057-8D	0.563 14.3	1.33 33.8	0.34 8.7	1.12 28.5
05	CP3057-10D	0.625 15.9	1.33 33.8	0.37 9.5	1.12 28.5
06	CP3057-12D	0.750 19.1	1.55 39.4	0.52 13.2	1.16 29.3
07	CP3057-16D	0.938 23.8	1.77 45.0	0.64 16.3	1.25 31.7
08	CP3057-20D	1.250 31.8	2.11 53.7	0.86 21.7	1.44 36.5
09	CP3057-24D	1.375 34.9	2.36 60.0	0.99 25.1	1.47 37.3
10	CP3057-28D	1.625 41.3	2.77 70.4	1.26 32.1	1.74 44.3
11	CP3057-32D	1.875 47.6	3.02 76.7	1.42 36.0	1.74 44.3

inches millimeters
Tolerance ±0.01±0.25

SERIES 61

Non-Submersible Cable Clamp Adapter Environmental, Non-Screened

COMPAERO

Angle 1 - Straight Rotatable Coupling, Type C Clamp

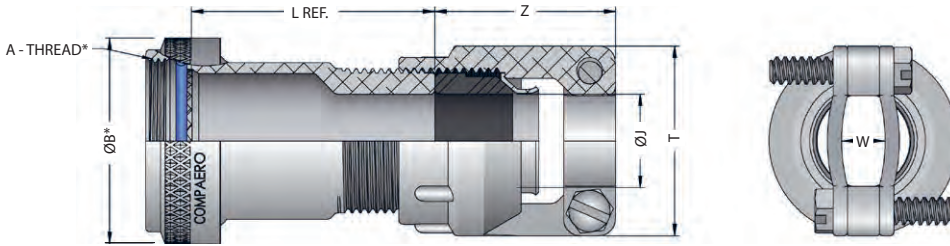

Clamp Option - Type E Nut



Angle 4 - 45 Degree

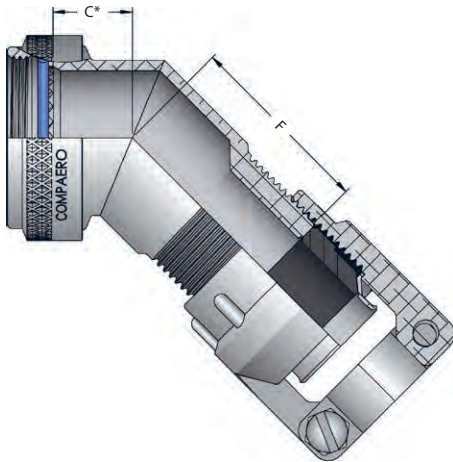

Angle 8 - 90 Degree

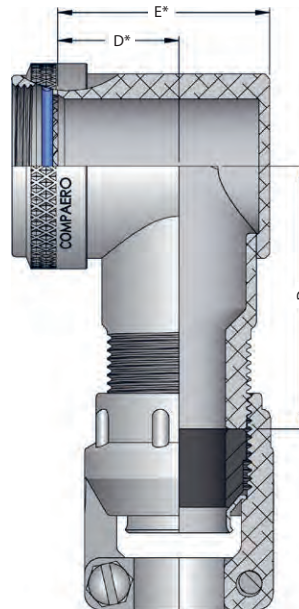

Angle 9 90 Degree Miter Cut

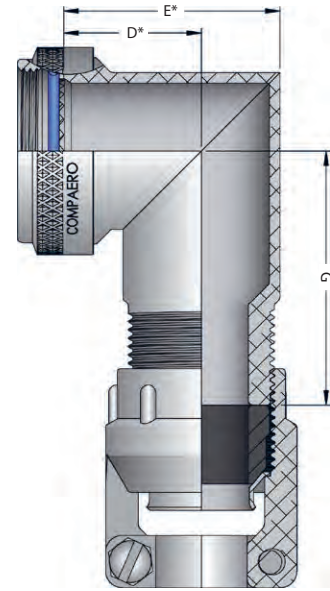

CP A 61 1 W D - 12 03 C - 10

Compaero Identifier

Connector Interface

See page 6 for details

Series Identifier

Angle

Material & Finish

See page 7 for details

Coupling Ring Option

Omit for standard rotatable

D - Direct coupling

E - Seat-lock (Non-detent, self locking)

S - Self locking (Detent, ratchet style)

T - Safety wire holes

W - Wrench flats

See page 8 for details

Length Option

Omit for 1.50" (Standard) & angled parts
0.25" Increments (10 = 2.50")

Cable Clamp Type

C - MS3057C (shown in drawings)

E - Style E

Cable Clamp Size

See table 2&3

Shell Size

See table 1

* Refer to interface tables in pages 43 & 44
inches [millimeters]



Table 1 Shell Size

SHELL SIZE	F MAX	G MAX
	in mm	in mm
08/09	0.88 22.4	1.17 29.7
10/11	0.91 23.1	1.23 31.2
12/13	0.93 23.6	1.29 32.8
14/15	0.96 24.4	1.35 34.3
16/17	0.98 24.9	1.42 36.1
18/19	1.00 25.4	1.45 36.8
20/21	1.02 25.9	1.51 38.4
22/23	1.05 26.7	1.57 39.9
24/25	1.07 27.2	1.63 41.4
28/29	1.10 27.9	1.70 43.2
32/33	1.15 29.2	1.82 46.2
36	1.19 30.2	1.92 48.8
40	1.24 31.5	2.04 51.8
44	1.29 32.8	2.17 55.1
48	1.35 34.3	2.29 58.2
61	1.06 26.9	1.60 40.6

Table 2 Type E Nut

ENTRY CODE	CLAMP REF	ØJ		Y MAX	
		in	mm	in	mm
01	CP3057-3E	0.250	6.4	0.58	14.8
02	CP3057-4E	0.313	7.9	0.58	14.8
03	CP3057-6E	0.438	11.1	0.58	14.8
04	CP3057-8E	0.563	14.3	0.58	14.8
05	CP3057-10E	0.625	15.9	0.60	15.3
06	CP3057-12E	0.750	19.1	0.68	17.2
07	CP3057-16E	0.938	23.8	0.66	16.8
08	CP3057-20E	1.250	31.8	0.73	18.6
09	CP3057-24E	1.375	34.9	0.97	24.5
10	CP3057-28E	1.625	41.3	0.96	24.4
11	CP3057-32E	1.875	47.6	1.08	27.4

Table 3 Type C Clamp

ENTRY CODE	CLAMP REF	ØJ		T MAX	W REF	Z MAX
		in	mm	in	mm	in
01	CP3057-3C	0.250	6.4	0.81 20.6	0.22 5.5	1.22 31.0
02	CP3057-4C	0.312	7.9	0.94 23.8	0.30 7.5	1.22 31.0
03	CP3057-6C	0.438	11.1	1.06 27.0	0.39 9.9	1.22 31.0
04	CP3057-8C	0.563	14.3	1.19 30.2	0.43 11.0	1.22 31.0
05	CP3057-10C	0.625	15.9	1.31 33.3	0.43 11.0	1.28 32.5
06	CP3057-12C	0.750	19.1	1.56 39.7	0.60 15.1	1.28 32.5
07	CP3057-16C	0.938	23.8	1.75 44.5	0.60 15.1	1.41 35.7
08	CP3057-20C	1.250	31.8	2.25 57.2	0.86 21.8	1.66 42.1
09	CP3057-24C	1.375	34.9	2.38 60.3	0.86 21.8	1.91 48.4
10	CP3057-28C	1.625	41.3	2.63 66.7	1.11 28.1	1.91 48.4
11	CP3057-32C	1.875	47.6	2.81 71.4	1.42 36.1	2.00 50.8

inches millimeters
Tolerance ±0.01±0.25

SERIES 70

EMI/RFI Cable Clamp Adapter Non-Environmental, Screened

COMPAERO

Angle 1 - Straight Rotatable Coupling, Type A Clamp

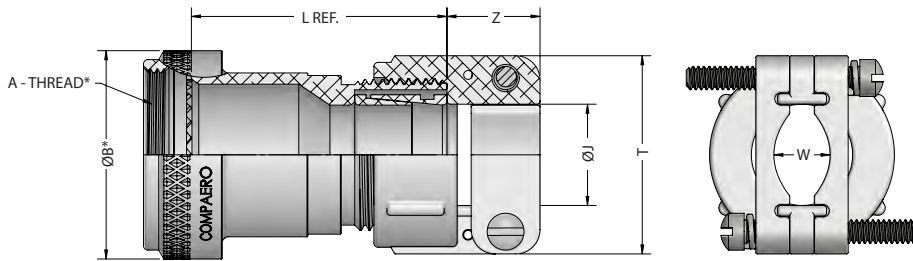

Clamp Option - Type H Clamp

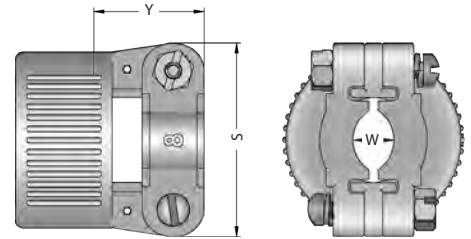

Angle 4 - 45 Degree

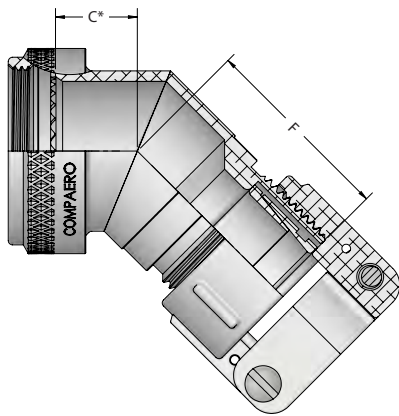

Angle 8 - 90 Degree

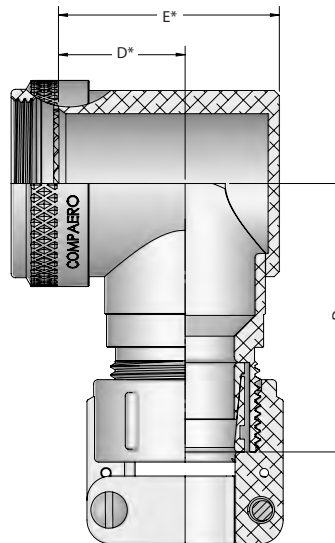

Angle 9 - 90 Degree Miter Cut

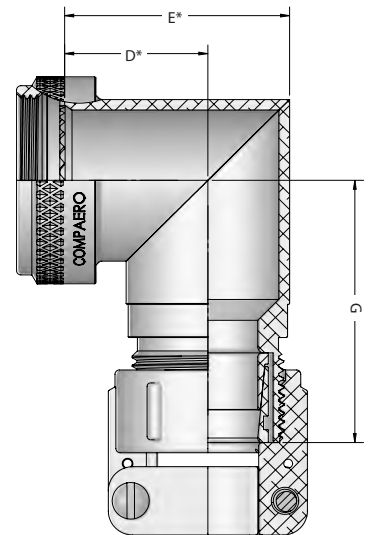

CP A 70 1 W D - 12 03 H - 10

Compaero Identifier

Connector Interface

See page 6 for details

Series Identifier

Angle

Material & Finish

See page 7 for details

Coupling Ring Option

Omit for standard rotatable

D - Direct coupling

E - Seat-lock (Non-detent, self locking)

S - Self locking (Detent, ratchet style)

T - Safety wire holes

W - Wrench flats

See page 8 for details

Length Option

Omit for 1.50" (Standard) & angled parts
0.25" Increments (10 = 2.50")

Cable Clamp Type

A - MS3057A (shown in drawings)

H - MS3057D

Cable Clamp Size

See table 2 & 3

Shell Size

See table 1

* Refer to interface tables in pages 43 & 44
inches [millimeters]

SERIES 70

EMI/RFI Cable Clamp Adapter Non-Environmental, Screened



Table 1 Shell Size

SHELL SIZE	F MAX	G MAX
	in mm	in mm
08/09	1.08 27.4	1.35 34.3
10/11	1.11 28.2	1.42 36.1
12/13	1.13 28.7	1.48 37.6
14/15	1.16 29.5	1.54 39.1
16/17	1.19 30.2	1.60 40.6
18/19	1.20 30.5	1.63 41.4
20/21	1.22 31.0	1.70 43.2
22/23	1.25 31.8	1.76 44.7
24/25	1.28 32.5	1.82 46.2
28/29	1.30 33.0	1.88 47.8
32/33	1.35 34.3	2.01 51.1
36	1.39 35.3	2.10 53.3
40	1.44 36.6	2.23 56.6
44	1.50 38.1	2.35 59.7
48	1.55 39.4	2.48 63.0
61	1.26 32.0	1.79 45.5

Table 2 Type A Clamp

ENTRY CODE	CLAMP REF	ØJ	T MAX	W REF	Z MAX
		in mm	in mm	in mm	in mm
01	CP3057-3A	0.250 6.4	0.84 21.4	0.16 4.0	0.80 20.2
02	CP3057-4A	0.312 7.9	0.91 23.0	0.19 4.8	0.80 20.2
03	CP3057-6A	0.438 11.1	1.09 27.8	0.28 7.1	0.86 21.8
04	CP3057-8A	0.563 14.3	1.19 30.1	0.34 8.7	0.92 23.4
05	CP3057-10A	0.625 15.9	1.28 32.5	0.38 9.5	0.92 23.4
06	CP3057-12A	0.750 19.1	1.50 38.1	0.44 11.1	0.92 23.4
07	CP3057-16A	0.938 23.8	1.72 43.7	0.56 14.3	1.02 25.8
08	CP3057-20A	1.250 31.8	2.06 52.4	0.75 19.1	1.02 25.8
09	CP3057-24A	1.375 34.9	2.31 58.7	0.78 19.8	1.02 25.8
10	CP3057-28A	1.625 41.3	2.72 69.1	0.97 24.6	1.55 39.3
11	CP3057-32A	1.875 47.6	2.97 75.4	1.13 28.6	1.55 39.3

Table 3 Type H Clamp

ENTRY CODE	CLAMP REF	ØJ	S MAX	W REF	Y MAX
		in mm	in mm	in mm	in mm
02	CP3057-4D	0.313 7.9	0.96 24.3	0.17 4.2	1.12 28.5
03	CP3057-6D	0.438 11.1	1.15 29.1	0.29 7.3	1.12 28.5
04	CP3057-8D	0.563 14.3	1.33 33.8	0.34 8.7	1.12 28.5
05	CP3057-10D	0.625 15.9	1.33 33.8	0.37 9.5	1.12 28.5
06	CP3057-12D	0.750 19.1	1.55 39.4	0.52 13.2	1.16 29.3
07	CP3057-16D	0.938 23.8	1.77 45.0	0.64 16.3	1.25 31.7
08	CP3057-20D	1.250 31.8	2.11 53.7	0.86 21.7	1.44 36.5
09	CP3057-24D	1.375 34.9	2.36 60.0	0.99 25.1	1.47 37.3
10	CP3057-28D	1.625 41.3	2.77 70.4	1.26 32.1	1.74 44.3
11	CP3057-32D	1.875 47.6	3.02 76.7	1.42 36.0	1.74 44.3

inches millimeters
Tolerance ±0.01±0.25

SERIES 73

EMI/RFI Cable Clamp Adapter Non-Environmental, Screened

COMPAERO

Angle 1 - Straight Rotatable Coupling, Type A Clamp

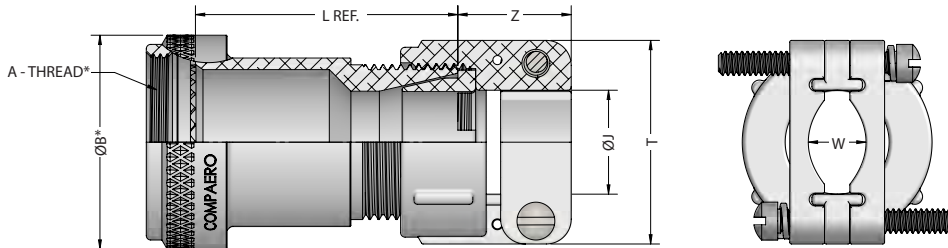

Clamp Option - Type H Clamp

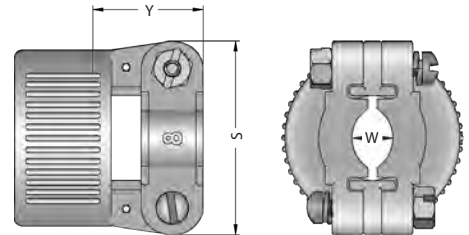

Angle 4 - 45 Degree

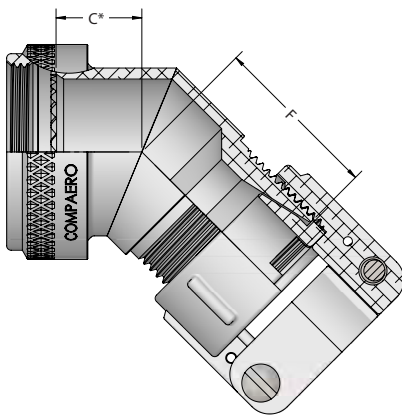

Angle 8 - 90 Degree

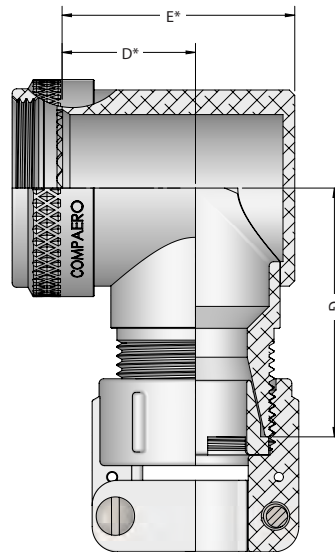

Angle 9 - 90 Degree Miter Cut

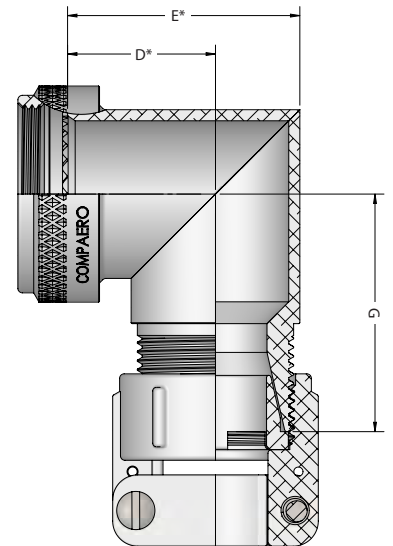

CP A 73 1 W D - 12 03 H - 10

Compaero Identifier

Connector Interface

See page 6 for details

Series Identifier

Angle

Material & Finish

See page 7 for details

Coupling Ring Option

Omit for standard rotatable

D - Direct coupling

E - Seat-lock (Non-detent, self locking)

S - Self locking (Detent, ratchet style)

T - Safety wire holes

W - Wrench flats

See page 8 for details

Length Option

Omit for 1.50" (Standard) & angled parts
0.25" Increments (10 = 2.50")

Cable Clamp Type

A - MS3057A (shown in drawings)

H - MS3057D

Cable Clamp Size

See table 2&3

Shell Size

See table 1

* Refer to interface tables in pages 43 & 44
inches [millimeters]



Table 1 Shell Size

SHELL SIZE	F MAX		G MAX	
	in	mm	in	mm
08/09	0.99	25.1	1.26	32.0
10/11	1.02	25.9	1.33	33.8
12/13	1.04	26.4	1.39	35.3
14/15	1.07	27.2	1.45	36.8
16/17	1.10	27.9	1.51	38.4
18/19	1.11	28.2	1.55	39.4
20/21	1.13	28.7	1.61	40.9
22/23	1.16	29.5	1.67	42.4
24/25	1.19	30.2	1.73	43.9
28/29	1.21	30.7	1.80	45.7
32/33	1.26	32.0	1.92	48.8
36	1.30	33.0	2.01	51.1
40	1.35	34.3	2.14	54.4
44	1.41	35.8	2.26	57.4
48	1.46	37.1	2.39	60.7
61	1.17	29.7	1.70	43.2

Table 2 Type A Clamp

ENTRY CODE	CLAMP REF	ØJ		T MAX		W REF		Z MAX	
		in	mm	in	mm	in	mm	in	mm
01	CP3057-3A	0.250	6.4	0.84	21.4	0.16	4.0	0.90	22.9
02	CP3057-4A	0.312	7.9	0.91	23.0	0.19	4.8	0.90	22.9
03	CP3057-6A	0.438	11.1	1.09	27.8	0.28	7.1	0.96	24.4
04	CP3057-8A	0.563	14.3	1.19	30.1	0.34	8.7	1.02	25.9
05	CP3057-10A	0.625	15.9	1.28	32.5	0.38	9.5	1.02	25.9
06	CP3057-12A	0.750	19.1	1.50	38.1	0.44	11.1	1.02	25.9
07	CP3057-16A	0.938	23.8	1.72	43.7	0.56	14.3	1.12	28.4
08	CP3057-20A	1.250	31.8	2.06	52.4	0.75	19.1	1.12	28.4
09	CP3057-24A	1.375	34.9	2.31	58.7	0.78	19.8	1.12	28.4
10	CP3057-28A	1.625	41.3	2.72	69.1	0.97	24.6	1.65	41.9
11	CP3057-32A	1.875	47.6	2.97	75.4	1.13	28.6	1.65	41.9

Table 3 Type H Clamp

ENTRY CODE	CLAMP REF	ØJ		S MAX		W REF		Y MAX	
		in	mm	in	mm	in	mm	in	mm
02	CP3057-4D	0.313	7.9	0.96	24.3	0.17	4.2	1.22	31.0
03	CP3057-6D	0.438	11.1	1.15	29.1	0.29	7.3	1.22	31.0
04	CP3057-8D	0.563	14.3	1.33	33.8	0.34	8.7	1.22	31.0
05	CP3057-10D	0.625	15.9	1.33	33.8	0.37	9.5	1.22	31.0
06	CP3057-12D	0.750	19.1	1.55	39.4	0.52	13.2	1.26	32.0
07	CP3057-16D	0.938	23.8	1.77	45.0	0.64	16.3	1.35	34.3
08	CP3057-20D	1.250	31.8	2.11	53.7	0.86	21.7	1.54	39.1
09	CP3057-24D	1.375	34.9	2.36	60.0	0.99	25.1	1.57	39.9
10	CP3057-28D	1.625	41.3	2.77	70.4	1.26	32.1	1.84	46.7
11	CP3057-32D	1.875	47.6	3.02	76.7	1.42	36.0	1.84	46.7

inches millimeters
Tolerance ±0.01±0.25

SERIES 80

Submersible EMI/RFI Cable Clamp Adapter Environmental, Screened

COMPAERO

Angle 1 - Straight Rotatable Coupling, Type A Clamp

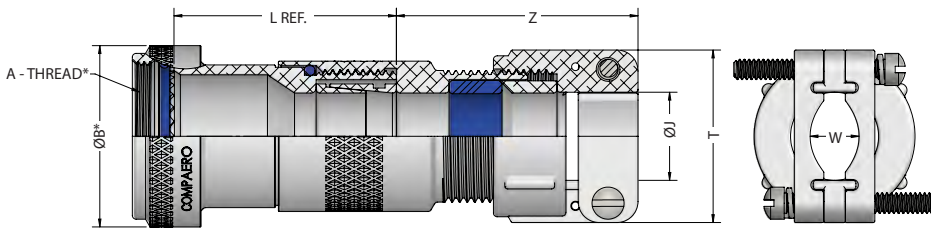

Clamp Option - Type H Clamp

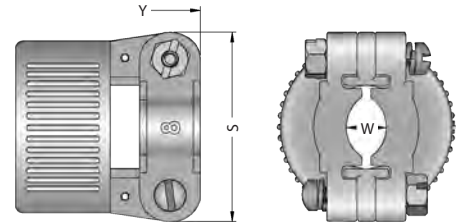

Angle 4 - 45 Degree

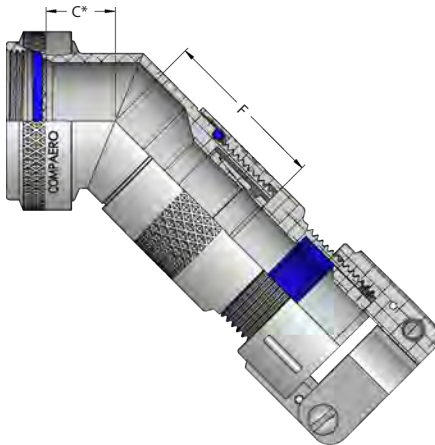

Angle 8 - 90 Degree

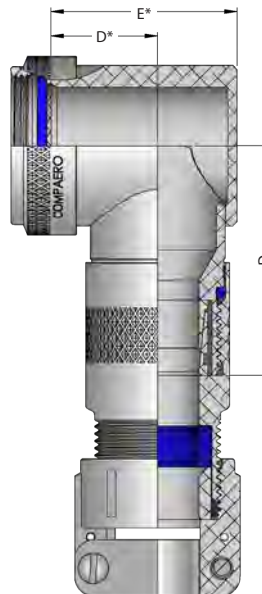

Angle 9 90 Degree Miter Cut

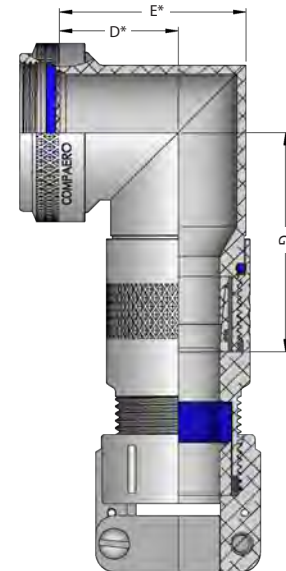

CP A 80 1 W D - 12 03 H - 10

Compaero Identifier

Connector Interface

See page 6 for details

Series Identifier

Angle

Material & Finish

See page 7 for details

Coupling Ring Option

Omit for standard rotatable

D - Direct coupling

E - Seat-lock (Non-detent, self locking)

S - Self locking (Detent, ratchet style)

T - Safety wire holes

W - Wrench flats

See page 8 for details

Length Option

Omit for 1.50" (Standard) & angled parts
0.25" Increments (10 = 2.50")

Cable Clamp Type

A - MS3057A (shown in drawings)

H - MS3057D

Cable Clamp Size

See table 2 & 3

Shell Size

See table 1

* Refer to interface tables in pages 43 & 44
inches [millimeters]



Table 1 Shell Size

SHELL SIZE	F MAX	G MAX
	in mm	in mm
08/09	1.08 27.4	1.35 34.3
10/11	1.11 28.2	1.42 36.1
12/13	1.13 28.7	1.48 37.6
14/15	1.16 29.5	1.54 39.1
16/17	1.19 30.2	1.60 40.6
18/19	1.20 30.5	1.63 41.4
20/21	1.22 31.0	1.70 43.2
22/23	1.25 31.8	1.76 44.7
24/25	1.28 32.5	1.82 46.2
28/29	1.30 33.0	1.88 47.8
32/33	1.35 34.3	2.01 51.1
36	1.39 35.3	2.10 53.3
40	1.44 36.6	2.23 56.6
44	1.50 38.1	2.35 59.7
48	1.55 39.4	2.48 63.0
61	1.26 32.0	1.79 45.5

Table 2 Type A Clamp

ENTRY CODE	CLAMP REF	ØJ	T MAX	W REF	Z MAX
		in mm	in mm	in mm	in mm
01	CP3057-3A	0.250 6.4	0.84 21.4	0.16 4.0	1.64 41.7
02	CP3057-4A	0.312 7.9	0.91 23.0	0.19 4.8	1.64 41.7
03	CP3057-6A	0.438 11.1	1.09 27.8	0.28 7.1	1.93 49.1
04	CP3057-8A	0.563 14.3	1.19 30.1	0.34 8.7	2.00 50.7
05	CP3057-10A	0.625 15.9	1.28 32.5	0.38 9.5	2.00 50.7
06	CP3057-12A	0.750 19.1	1.50 38.1	0.44 11.1	2.00 50.7
07	CP3057-16A	0.938 23.8	1.72 43.7	0.56 14.3	2.09 53.1
08	CP3057-20A	1.250 31.8	2.06 52.4	0.75 19.1	2.09 53.1
09	CP3057-24A	1.375 34.9	2.31 58.7	0.78 19.8	2.09 53.1
10	CP3057-28A	1.625 41.3	2.72 69.1	0.97 24.6	2.62 66.6
11	CP3057-32A	1.875 47.6	2.97 75.4	1.13 28.6	2.62 66.6

Table 3 Type H Clamp

ENTRY CODE	CLAMP REF	ØJ	S MAX	W REF	Y MAX
		in mm	in mm	in mm	in mm
02	CP3057-4D	0.313 7.9	0.96 24.3	0.17 4.2	1.97 50.0
03	CP3057-6D	0.438 11.1	1.15 29.1	0.29 7.3	2.20 55.8
04	CP3057-8D	0.563 14.3	1.33 33.8	0.34 8.7	2.20 55.8
05	CP3057-10D	0.625 15.9	1.33 33.8	0.37 9.5	2.20 55.8
06	CP3057-12D	0.750 19.1	1.55 39.4	0.52 13.2	2.23 56.6
07	CP3057-16D	0.938 23.8	1.77 45.0	0.64 16.3	2.32 59.0
08	CP3057-20D	1.250 31.8	2.11 53.7	0.86 21.7	2.51 63.8
09	CP3057-24D	1.375 34.9	2.36 60.0	0.99 25.1	2.54 64.6
10	CP3057-28D	1.625 41.3	2.77 70.4	1.26 32.1	2.82 71.6
11	CP3057-32D	1.875 47.6	3.02 76.7	1.42 36.0	2.82 71.6

inches millimeters
Tolerance ±0.01±0.25

Angle 1 - Straight Rotatable Coupling, Type C Clamp

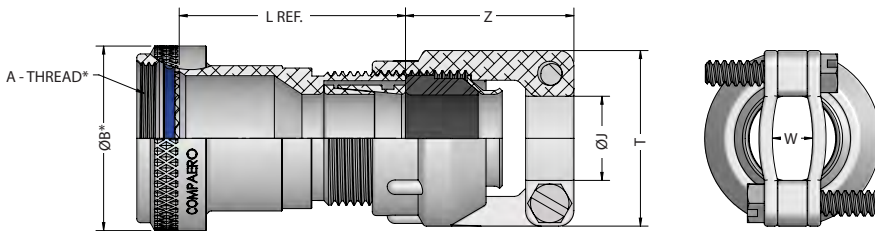

Clamp Option - Type E Nut

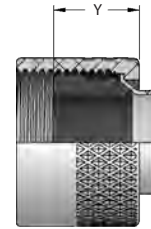

Angle 4 - 45 Degree

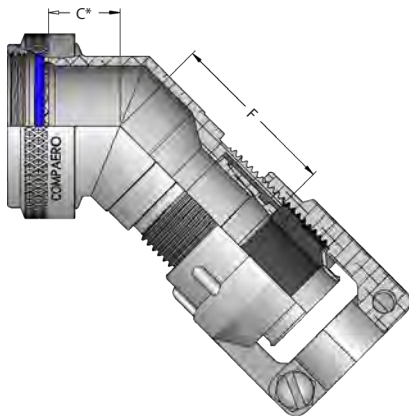

Angle 8 - 90 Degree

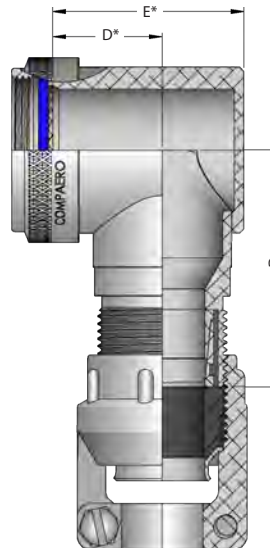

Angle 9 - 90 Degree Miter Cut

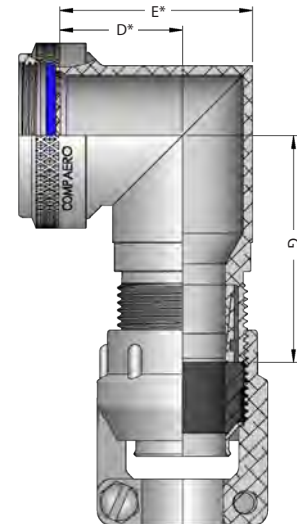

CP A 81 1 W D - 12 03 C - 10

Compaero Identifier

Connector Interface

See page 6 for details

Series Identifier

Angle

Material & Finish

See page 7 for details

Coupling Ring Option

Omit for standard rotatable

D - Direct coupling

E - Seat-lock (Non-detent, self locking)

S - Self locking (Detent, ratchet style)

T - Safety wire holes

W - Wrench flats

See page 8 for details

Length Option

Omit for 1.50" (Standard) & angled parts
0.25" Increments (10 = 2.50")

Cable Clamp Type

C - MS3057C (shown in drawings)

E - STYLE "E"

Cable Clamp Size

See table 2 & 3

Shell Size

See table 1

* Refer to interface tables in pages 43 & 44
inches [millimeters]



Table 1 Shell Size

SHELL SIZE	F MAX	G MAX
	in mm	in mm
08/09	1.08 27.4	1.35 34.3
10/11	1.11 28.2	1.42 36.1
12/13	1.13 28.7	1.48 37.6
14/15	1.16 29.5	1.54 39.1
16/17	1.19 30.2	1.60 40.6
18/19	1.20 30.5	1.63 41.4
20/21	1.22 31.0	1.70 43.2
22/23	1.25 31.8	1.76 44.7
24/25	1.28 32.5	1.82 46.2
28/29	1.30 33.0	1.88 47.8
32/33	1.35 34.3	2.01 51.1
36	1.39 35.3	2.10 53.3
40	1.44 36.6	2.23 56.6
44	1.50 38.1	2.35 59.7
48	1.55 39.4	2.48 63.0
61	1.26 32.0	1.79 45.5

Table 2 Type E Nut

ENTRY CODE	CLAMP REF	ØJ		Y MAX	
		in	mm	in	mm
01	CP3057-3E	0.250	6.4	0.79	20.0
02	CP3057-4E	0.313	7.9	0.79	20.0
03	CP3057-6E	0.438	11.1	0.79	20.0
04	CP3057-8E	0.563	14.3	0.79	20.1
05	CP3057-10E	0.625	15.9	0.81	20.5
06	CP3057-12E	0.750	19.1	0.88	22.4
07	CP3057-16E	0.938	23.8	0.87	22.0
08	CP3057-20E	1.250	31.8	0.94	23.9
09	CP3057-24E	1.375	34.9	1.17	29.8
10	CP3057-28E	1.625	41.3	1.17	29.7
11	CP3057-32E	1.875	47.6	1.29	32.7

Table 3 Type C Clamp

ENTRY CODE	CLAMP REF	ØJ		T MAX	W REF	Z MAX
		in	mm	in	mm	in
01	CP3057-3C	0.250	6.4	0.81 20.6	0.22 5.5	1.42 36.2
02	CP3057-4C	0.312	7.9	0.94 23.8	0.30 7.5	1.42 36.2
03	CP3057-6C	0.438	11.1	1.06 27.0	0.39 9.9	1.42 36.2
04	CP3057-8C	0.563	14.3	1.19 30.2	0.43 11.0	1.42 36.2
05	CP3057-10C	0.625	15.9	1.31 33.3	0.43 11.0	1.49 37.8
06	CP3057-12C	0.750	19.1	1.56 39.7	0.60 15.1	1.49 37.8
07	CP3057-16C	0.938	23.8	1.75 44.5	0.60 15.1	1.61 40.9
08	CP3057-20C	1.250	31.8	2.25 57.2	0.86 21.8	1.86 47.3
09	CP3057-24C	1.375	34.9	2.38 60.3	0.86 21.8	2.11 53.6
10	CP3057-28C	1.625	41.3	2.63 66.7	1.11 28.1	2.11 53.6
11	CP3057-32C	1.875	47.6	2.81 71.4	1.42 36.1	2.21 56.0

inches millimeters
Tolerance ±0.01±0.25

SERIES 82

Submersible EMI/RFI Cable Clamp Adapter Environmental, Screened

COMPAERO

Angle 1 - Straight Rotatable Coupling, Type A Clamp

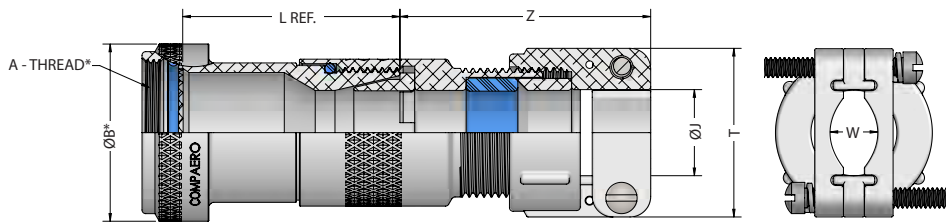

Clamp Option - Type H Clamp

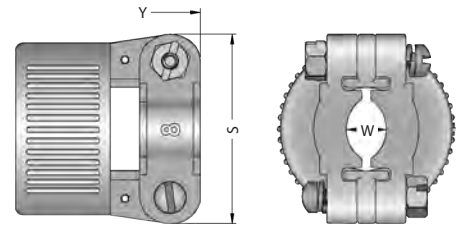

Angle 4 - 45 Degree

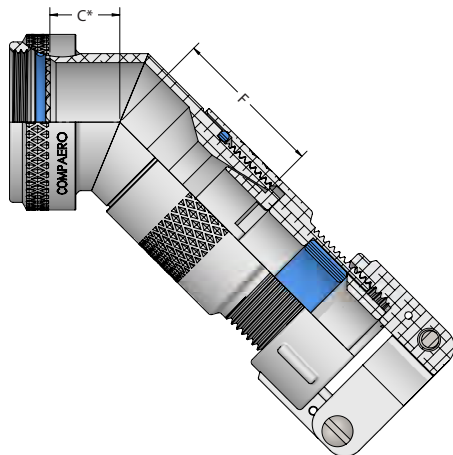

Angle 8 - 90 Degree

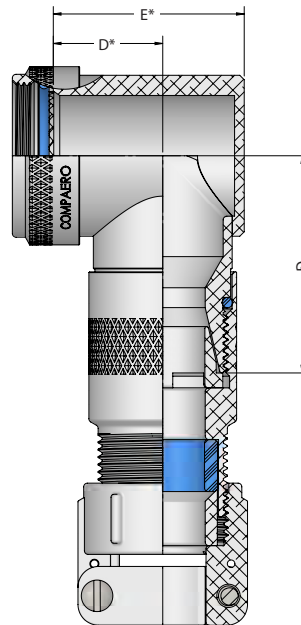

Angle 9 - 90 Degree Miter Cut

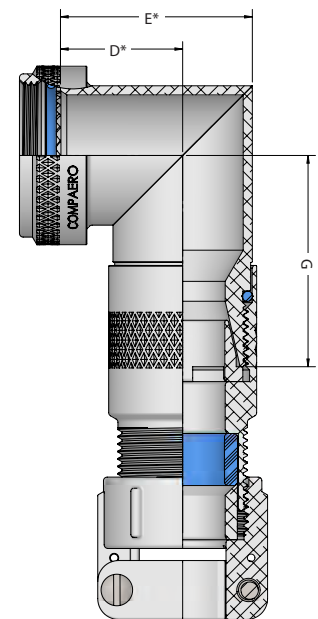

CP A 82 1 W D - 12 03 H - 10

Compaero Identifier

Connector Interface

See page 6 for details

Series Identifier

Angle

Material & Finish

See page 7 for details

Coupling Ring Option

Omit for standard rotatable

D - Direct coupling

E - Seat-lock (Non-detent, self locking)

S - Self locking (Detent, ratchet style)

T - Safety wire holes

W - Wrench flats

See page 8 for details

Length Option

Omit for 1.50" (Standard) & angled parts
0.25" Increments (10 = 2.50")

Cable Clamp Type

A - MS3057A (shown in drawings)

H - MS3057D

Cable Clamp Size

See table 2&3

Shell Size

See table 1

* Refer to interface tables in pages 43 & 44
inches [millimeters]



Table 1 Shell Size

SHELL SIZE	F MAX		G MAX	
	in	mm	in	mm
08/09	0.99	25.1	1.26	32.0
10/11	1.02	25.9	1.33	33.8
12/13	1.04	26.4	1.39	35.3
14/15	1.07	27.2	1.45	36.8
16/17	1.10	27.9	1.51	38.4
18/19	1.11	28.2	1.55	39.4
20/21	1.13	28.7	1.61	40.9
22/23	1.16	29.5	1.67	42.4
24/25	1.19	30.2	1.73	43.9
28/29	1.21	30.7	1.80	45.7
32/33	1.26	32.0	1.92	48.8
36	1.30	33.0	2.01	51.1
40	1.35	34.3	2.14	54.4
44	1.41	35.8	2.26	57.4
48	1.46	37.1	2.39	60.7
61	1.17	29.7	1.70	43.2

Table 2 Type A Clamp

ENTRY CODE	CLAMP REF	ØJ		T MAX		W REF		Z MAX	
		in	mm	in	mm	in	mm	in	mm
01	CP3057-3A	0.250	6.4	0.84	21.4	0.16	4.0	1.74	44.2
02	CP3057-4A	0.312	7.9	0.91	23.0	0.19	4.8	1.74	44.2
03	CP3057-6A	0.438	11.1	1.09	27.8	0.28	7.1	2.03	51.6
04	CP3057-8A	0.563	14.3	1.19	30.1	0.34	8.7	2.10	53.3
05	CP3057-10A	0.625	15.9	1.28	32.5	0.38	9.5	2.10	53.3
06	CP3057-12A	0.750	19.1	1.50	38.1	0.44	11.1	2.10	53.3
07	CP3057-16A	0.938	23.8	1.72	43.7	0.56	14.3	2.19	55.6
08	CP3057-20A	1.250	31.8	2.06	52.4	0.75	19.1	2.19	55.6
09	CP3057-24A	1.375	34.9	2.31	58.7	0.78	19.8	2.19	55.6
10	CP3057-28A	1.625	41.3	2.72	69.1	0.97	24.6	2.72	69.1
11	CP3057-32A	1.875	47.6	2.97	75.4	1.13	28.6	2.72	69.1

Table 3 Type H Clamp

ENTRY CODE	CLAMP REF	ØJ		S MAX		W REF		Y MAX	
		in	mm	in	mm	in	mm	in	mm
02	CP3057-4D	0.313	7.9	0.96	24.3	0.17	4.2	2.07	52.6
03	CP3057-6D	0.438	11.1	1.15	29.1	0.29	7.3	2.30	58.4
04	CP3057-8D	0.563	14.3	1.33	33.8	0.34	8.7	2.30	58.4
05	CP3057-10D	0.625	15.9	1.33	33.8	0.37	9.5	2.30	58.4
06	CP3057-12D	0.750	19.1	1.55	39.4	0.52	13.2	2.33	59.2
07	CP3057-16D	0.938	23.8	1.77	45.0	0.64	16.3	2.42	61.5
08	CP3057-20D	1.250	31.8	2.11	53.7	0.86	21.7	2.61	66.3
09	CP3057-24D	1.375	34.9	2.36	60.0	0.99	25.1	2.64	67.1
10	CP3057-28D	1.625	41.3	2.77	70.4	1.26	32.1	2.92	74.2
11	CP3057-32D	1.875	47.6	3.02	76.7	1.42	36.0	2.92	74.2

inches millimeters
Tolerance ±0.01±0.25



Compaero supply and manufacture a comprehensive range of stainless steel termination bands to be used in a wide variety of interconnect systems. Qualified to the AS85049 standard, they provide a reliable and cost effective termination solution, available in both flat and pre-coiled versions.

CPTB-1 Stamped Buckle Option

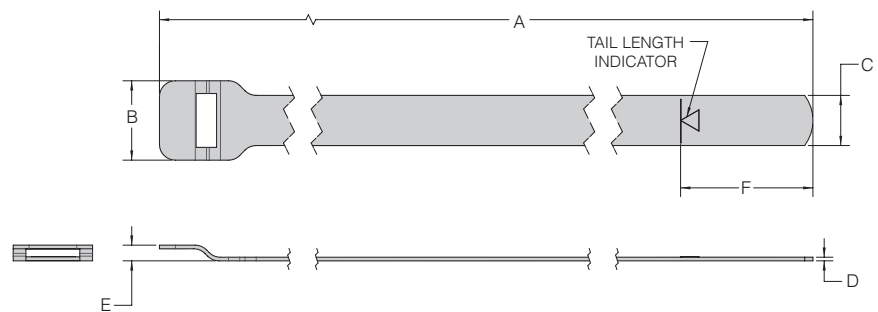

PART NUMBER	A	B	C	D REF	E REF	F REF
	± .060" / 1.52mm	± .031" / 0.79mm	± .010" / 0.26mm			
CPTB-111*	14.25 361.95	0.350 8.89	0.250 6.35	0.020 0.51	0.130 3.30	2.031 51.59
CPTB-112	18.00 457.2	0.350 8.89	0.250 6.35	0.020 0.51	0.130 3.30	2.031 51.59
CPTB-121*	8.125 206.38	0.195 4.95	0.120 3.05	0.015 0.38	0.053 1.35	2.031 51.59
CPTB-122	14.25 361.95	0.195 4.95	0.120 3.05	0.015 0.38	0.053 1.35	2.031 51.59

*Available as qualified M85049/128 product - see website for details

CPTB-2 Welded Buckle Option

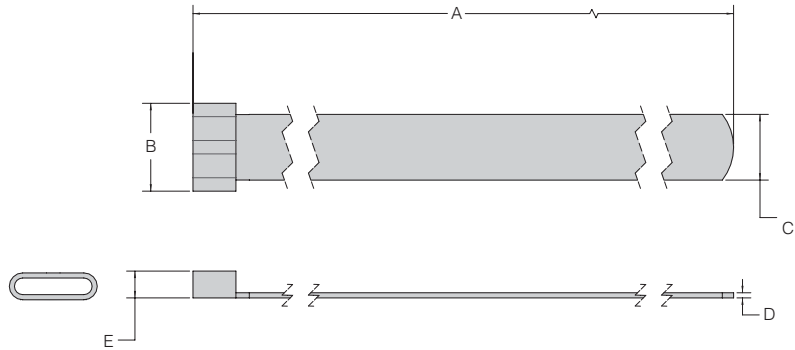

PART NUMBER	A	B	C	D REF	E REF
	± .060" / 1.52mm	± .031" / 0.79mm	± .010" / 0.26mm		
CPTB-211*	14.00 355.60	0.328 8.33	0.245 6.22	0.019 0.50	0.100 2.54
CPTB-212	18.00 457.20	0.328 8.33	0.245 6.22	0.019 0.50	0.100 2.54
CPTB-221*	9.50 241.30	0.198 5.03	0.118 2.99	0.015 0.40	0.080 2.03
CPTB-222	14.25 361.95	0.198 5.03	0.118 2.99	0.015 0.40	0.080 2.03

*Available as qualified M85049/128 product - see website for details

Notes:

1. Optional part marking available - contact sales team for details
2. Material: 300 series stainless steel, passivated

Part Numbering System:

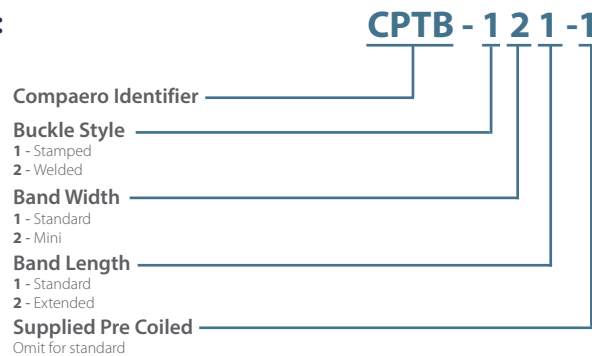

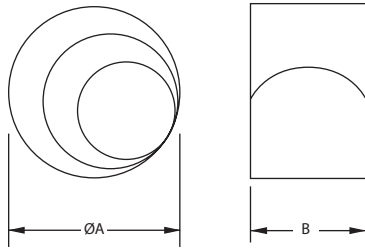

Stainless Steel Constant Force Spring Band Option

- Re-usable and self-tensioning to secure both overall and individual braid termination.
- Easy to install - requires no tooling while providing a high level of tensile strength to the assembly.
- Suitable for corrosive environments and are not affected by vibration, shock or extreme temperatures.

Use Compaero Order Code 'S' to have a constant spring band included with the adapter. Compaero will determine the appropriate size needed based on the Cable Entry called out on the part number.

ENTRY	BAND REF	A MAX		B		TURNS ±0.25
		in	mm	in	mm	
S	ISOC	0.235	5.97	0.370	9.4	
S	ISO1	0.353	8.96	0.370	9.4	4.5
S	ISO2	0.605	15.36	0.370	9.4	3.5
S	ISO4	0.755	19.17	0.370	9.4	4.5
S	ISO5	1.048	26.61	0.370	9.4	3.5

inches millimeters
Tolerance ±0.01±0.25



Memory Ring Option

- Low-profile, high-strength, shape-memory-alloy shield termination device
- Available in many sizes to accommodate various entry sizes and shield configurations
- Ideal for lightweight aerospace applications requiring repeated high-to-low temperature cycles.

See Series 49 (page 22) for full Memory Ring Adapter details.

SIZE	CABLE ENTRY	ADAPTER ØK	AI			BI	
			AS SUPPLIED	RECOVERED	AS SUPPLIED	RECOVERED	
			in	mm	in	mm	in
04	02	0.373 9.5	0.397 10.1	0.379 9.7	0.416 10.6	0.398 10.2	
05	32	0.435 11.1	0.460 11.7	0.440 11.2	0.479 12.2	0.458 11.7	
06	03	0.498 12.7	0.523 13.3	0.499 12.7	0.548 14.0	0.523 13.3	
07	33	0.560 14.3	0.586 14.9	0.559 14.2	0.606 15.4	0.578 14.7	
08	04	0.623 15.9	0.650 16.6	0.620 15.8	0.670 17.1	0.639 16.3	
10	05	0.747 19.0	0.782 19.9	0.744 18.9	0.802 20.4	0.763 19.4	
12	06	0.872 22.2	0.912 23.2	0.867 22.1	0.931 23.7	0.886 22.6	
14	07	0.997 25.4	1.040 26.5	0.988 25.1	1.060 27.0	1.007 25.6	
16	08	1.122 28.5	1.171 29.8	1.111 28.3	1.191 30.3	1.129 28.7	
18	09	1.247 31.7	1.301 33.1	1.234 31.4	1.320 33.6	1.252 31.9	
20	10	1.372 34.9	1.430 36.4	1.357 34.5	1.450 36.9	1.376 35.0	
22	11	1.495 38.0	1.543 39.2	1.463 37.2	1.561 39.7	1.481 37.7	
24	12	1.620 41.2	1.673 42.5	1.587 40.4	1.691 43.0	1.605 40.8	

Part Numbering System:

CPTR 08 AI

Compaero Identifier

Size

Memory Ring Style

AI - Ring accommodates a single 36 AWG braid per QQB-575

BI - Ring accommodates a single 30 AWG braid or double 36 AWG braids per QQB-575

INTERFACE TABLE

Reference tables for catalogue series

ADAPTER SHELL SIZE	CONNECTOR SHELL SIZE	A THREAD	ØB MAX	C MAX	D MAX	E MAX	MAX ENTRY
			in mm	in mm	in mm	in mm	
08	8S	7/16-27UNS	0.75 19.2	0.59 15.0	0.72 18.3	1.02 25.9	32
10	10S	1/2-28UNEF	0.82 20.8	0.60 15.4	0.75 19.1	1.08 27.5	03
11	10SL	5/8-24UNEF	0.94 23.9	0.63 16.0	0.81 20.7	1.21 30.6	04
12	12, 12S	11/16-24UNEF	1.02 25.9	0.64 16.3	0.84 21.5	1.27 32.2	34
14	14, 14S	3/4-20UNEF	1.08 27.5	0.66 16.7	0.88 22.2	1.33 33.8	05
16	16, 16S	7/8-20UNEF	1.27 32.3	0.71 18.1	0.97 24.6	1.49 37.8	06
18	18	1-20UNEF	1.40 35.4	0.74 18.8	1.03 26.2	1.61 40.9	36
20	20	1 1/8-18UNEF	1.52 38.6	0.77 19.4	1.09 27.8	1.74 44.1	08
22	22	1 1/4-18UNEF	1.65 41.8	0.79 20.1	1.16 29.4	1.86 47.3	09
24	24	1 3/8-18UNEF	1.85 46.9	0.85 21.5	1.25 31.8	2.02 51.3	10
28	28	1 5/8-18UNEF	1.97 50.1	0.87 22.2	1.31 33.4	2.14 54.4	11
32	32	1 29/32-18UN	2.22 56.4	0.93 23.5	1.44 36.5	2.39 60.8	13
36	36	2 1/8-18UNS	2.55 64.8	1.01 25.6	1.59 40.5	2.67 67.9	15
40	40	2 3/8-16UN	2.80 71.2	1.06 26.9	1.72 43.7	2.92 74.3	-
44	44	2 5/8-16UN	3.05 77.5	1.11 28.3	1.84 46.9	3.17 80.6	-
48	48	2 7/8-16UN	3.38 85.9	1.20 30.4	2.00 50.8	3.46 87.8	-

ADAPTER SHELL SIZE	CONNECTOR SHELL SIZE	A THREAD	ØB MAX	C MAX	D MAX	E MAX	MAX ENTRY
			in mm	in mm	in mm	in mm	
08	8S	7/16-28UNEF	0.75 19.2	0.59 15.0	0.72 18.3	1.02 25.9	32
10	10S	1/2-28UNEF	0.82 20.8	0.60 15.4	0.75 19.1	1.08 27.5	03
11	10SL	9/16-24UNEF	0.88 22.3	0.62 15.7	0.78 19.9	1.14 29.0	33
12	12, 12S	5/8-24UNEF	0.94 23.9	0.63 16.0	0.81 20.7	1.21 30.6	04
14	14, 14S	3/4-20UNEF	1.08 27.5	0.66 16.7	0.88 22.2	1.33 33.8	34
16	16, 16S	7/8-20UNEF	1.27 32.3	0.71 18.1	0.97 24.6	1.49 37.8	35
18	18	1-20UNEF	1.40 35.4	0.74 18.8	1.03 26.2	1.61 40.9	36
20	20	1 1/8-18UNEF	1.52 38.6	0.77 19.4	1.09 27.8	1.74 44.1	37
22	22	1 1/4-18UNEF	1.65 41.8	0.79 20.1	1.16 29.4	1.86 47.3	38
24	24	1 3/8-18UNEF	1.85 46.9	0.85 21.5	1.25 31.8	2.02 51.3	09
28	28	1 5/8-18UNEF	1.97 50.1	0.87 22.2	1.31 33.4	2.14 54.4	11
32	32	1 7/8-16UN	2.22 56.4	0.93 23.5	1.44 36.5	2.39 60.8	13
36	36	2 1/8-16UN	2.55 64.8	1.01 25.6	1.59 40.5	2.67 67.9	15
40	40	2 3/8-16UN	2.80 71.2	1.06 26.9	1.72 43.7	2.92 74.3	-
44	44	2 5/8-16UN	3.05 77.5	1.11 28.3	1.84 46.9	3.17 80.6	-
48	48	2 13/16-18UNS	3.38 85.9	1.20 30.4	2.00 50.8	3.46 87.8	-

ADAPTER SHELL SIZE	CONNECTOR SHELL SIZE	A THREAD	ØB MAX	C MAX	D MAX	E MAX	MAX ENTRY
			in mm	in mm	in mm	in mm	
08	8S	7/16-27UNS	0.75 19.2	0.59 15.0	0.72 18.3	1.02 25.9	32
10	10S	1/2-28UNEF	0.82 20.8	0.60 15.4	0.75 19.1	1.08 27.5	03
11	10SL	5/8-24UNEF	0.94 23.9	0.63 16.0	0.81 20.7	1.21 30.6	04
12	12, 12S	11/16-24UNEF	1.02 25.9	0.64 16.3	0.84 21.5	1.27 32.2	34
14	14, 14S	3/4-20UNEF	1.08 27.5	0.66 16.7	0.88 22.2	1.33 33.8	05
16	16, 16S	7/8-20UNEF	1.27 32.3	0.71 18.1	0.97 24.6	1.49 37.8	06
18	18	1-20UNEF	1.40 35.4	0.74 18.8	1.03 26.2	1.61 40.9	36
20	20	1 1/8-24UNS	1.52 38.6	0.77 19.4	1.09 27.8	1.74 44.1	08
22	22	1 1/4-18UNEF	1.65 41.8	0.79 20.1	1.16 29.4	1.86 47.3	09
24	24	1 3/8-18UNEF	1.85 46.9	0.85 21.5	1.25 31.8	2.02 51.3	10
28	28	1 5/8-18UNEF	1.97 50.1	0.87 22.2	1.31 33.4	2.14 54.4	11
32	32	1 29/32-18UN	2.22 56.4	0.93 23.5	1.44 36.5	2.39 60.8	13
36	36	2 1/16-20UNS	2.55 64.8	1.01 25.6	1.59 40.5	2.67 67.9	15
40	40	2 3/8-16UN	2.80 71.2	1.06 26.9	1.72 43.7	2.92 74.3	-
44	44	2 5/8-16UN	3.05 77.5	1.11 28.3	1.84 46.9	3.17 80.6	-
48	48	2 7/8-16UN	3.38 85.9	1.20 30.4	2.00 50.8	3.46 87.8	-

ADAPTER SHELL SIZE	CONNECTOR SHELL SIZE	A THREAD	ØB MAX	C MAX	D MAX	E MAX	MAX ENTRY
			in mm	in mm	in mm	in mm	
08	8S	3/8-32UNEF	0.69 17.6	0.58 14.7	0.69 17.5	0.96 24.3	02
10	10S	1/2-28UNEF	0.82 20.8	0.60 15.4	0.75 19.1	1.08 27.5	03
11	10SL	5/8-24UNEF	0.94 23.9	0.63 16.0	0.81 20.7	1.21 30.6	04
12	12, 12S	5/8-24UNEF	0.94 23.9	0.63 16.0	0.81 20.7	1.21 30.6	04
14	14, 14S	3/4-20UNEF	1.08 27.5	0.66 16.7	0.88 22.2	1.33 33.8	05
16	16, 16S	7/8-20UNEF	1.27 32.3	0.71 18.1	0.97 24.6	1.49 37.8	06
18	18	1-20UNEF	1.40 35.4	0.74 18.8	1.03 26.2	1.61 40.9	36
20	20	1 1/8-18UNEF	1.52 38.6	0.77 19.4	1.09 27.8	1.74 44.1	08
22	22	1 1/4-18UNEF	1.65 41.8	0.79 20.1	1.16 29.4	1.86 47.3	09
24	24	1 3/8-18UNEF	1.85 46.9	0.85 21.5	1.25 31.8	2.02 51.3	10
28	28	1 5/8-18UNEF	1.97 50.1	0.87 22.2	1.31 33.4	2.14 54.4	11
32	32	1 7/8-16UN	2.22 56.4	0.93 23.5	1.44 36.5	2.39 60.8	13
36	36	2 1/16-16UNS	2.55 64.8	1.01 25.6	1.59 40.5	2.67 67.9	15
40	40	2 5/16-16UNS	2.80 71.2	1.06 26.9	1.72 43.7	2.92 74.3	-
44	44	2 5/8-16UN	3.05 77.5	1.11 28.3	1.84 46.9	3.17 80.6	-

INTERFACE TABLE

Reference tables for catalogue series

SHELL SIZE	A THREAD	ØB MAX		C MAX		D MAX		E MAX		MAX ENTRY
		in	mm	in	mm	in	mm	in	mm	
08	1/2-20 UNF	0.69	17.6	0.54	13.6	0.65	16.5	0.92	23.4	02
10	5/8-24 UNEF	0.81	20.5	0.57	14.4	0.70	17.9	1.03	26.3	03
12	3/4-20 UNEF	0.94	24.0	0.58	14.8	0.77	19.6	1.16	29.4	04
14	7/8-20 UNEF	1.07	27.1	0.60	15.3	0.84	21.4	1.22	30.9	34
16	1-20 UNEF	1.24	31.6	0.63	15.9	0.90	22.9	1.34	34.1	35
18	1 1/16-18 UNEF	1.32	33.4	0.64	16.4	0.93	23.6	1.40	35.4	06
20	1 3/16-18 UNEF	1.44	36.6	0.67	17.0	0.99	25.2	1.52	38.6	07
22	1 5/16-18 UNEF	1.57	39.8	0.70	17.7	1.06	26.8	1.65	41.8	08
24	1 7/16-18 UNEF	1.69	43.0	0.73	18.5	1.12	28.4	1.77	45.0	09
28	1 3/4-18 UNS	2.00	50.9	0.83	21.2	1.28	32.6	2.06	52.4	11
32	2-18 UNS	2.25	57.2	0.89	22.6	1.41	35.8	2.31	58.7	13
36	2 1/4-16 UN	2.50	63.6	0.93	23.7	1.53	39.0	2.53	64.3	14
40	2 1/2-16UN	2.75	69.9	1.01	25.6	1.66	42.1	2.78	70.6	16
44	2 3/4-16UN	3.00	76.3	1.06	26.9	1.78	45.3	3.03	77.0	-
48	3-16UN	3.25	82.6	1.11	28.2	1.91	48.5	3.28	83.3	-
61	1 1/2-18UNEF	1.75	44.5	0.77	19.4	1.16	29.4	1.84	46.8	09

SHELL SIZE	A THREAD	ØB MAX		C MAX		D MAX		E MAX		MAX ENTRY
		in	mm	in	mm	in	mm	in	mm	
08	7/16-28UNEF	0.68	17.3	0.57	14.4	0.72	18.2	1.00	25.5	02
10	9/16-24UNEF	0.80	20.3	0.59	14.9	0.86	21.8	1.16	29.5	03
12	11/16-24UNEF	0.94	23.8	0.62	15.7	0.83	21.0	1.26	32.0	04
14	13/16-20UNEF	1.06	26.8	0.65	16.5	0.92	23.4	1.40	35.5	05
16	15/16-20UNEF	1.17	29.8	0.66	16.8	0.96	24.5	1.52	38.5	06
18	1 1/16-18UNEF	1.31	33.3	0.70	17.8	1.04	26.5	1.65	42.0	07
20	1 3/16-18UNEF	1.43	36.3	0.71	18.1	1.12	28.5	1.79	45.5	08
22	1 5/16-18UNEF	1.57	39.8	0.73	18.5	1.18	30.0	1.91	48.5	09
24	1 7/16-18UNEF	1.69	42.8	0.78	19.7	1.24	31.5	2.03	51.5	10

SHELL SIZE	A THREAD	ØB MAX		C MAX		D MAX		E MAX		MAX ENTRY
		in	mm	in	mm	in	mm	in	mm	
08	7/16-28UNEF	0.66	16.8	0.50	12.7	0.60	15.3	0.87	22.1	02
10	9/16-24UNEF	0.80	20.3	0.52	13.3	0.67	16.9	1.00	25.3	03
12	11/16-24UNEF	0.92	23.4	0.55	13.9	0.73	18.5	1.12	28.4	04
14	13/16-20UNEF	1.06	26.8	0.58	14.7	0.79	20.1	1.25	31.6	05
16	15/16-20UNEF	1.18	30.0	0.60	15.4	0.85	21.7	1.37	34.8	06
18	1 1/16-18UNEF	1.31	33.3	0.61	15.4	0.92	23.2	1.50	38.0	07
20	1 3/16-18UNEF	1.44	36.5	0.66	16.7	0.98	24.8	1.62	41.1	08
22	1 5/16-18UNEF	1.56	39.7	0.68	17.4	1.04	26.4	1.75	44.3	09
24	1 7/16-18UNEF	1.69	42.9	0.68	17.4	1.10	28.0	1.87	47.5	10

SHELL SIZE	A THREAD	ØB MAX		C MAX		D MAX		E MAX		MAX ENTRY
		in	mm	in	mm	in	mm	in	mm	
11	3/4-20UNEF	1.04	26.5	0.80	20.4	0.95	24.1	1.28	32.5	03
13	7/8-20UNEF	1.17	29.7	0.83	21.0	1.01	25.7	1.40	35.6	04
15	1-20UNEF	1.23	31.3	0.85	21.7	1.07	27.2	1.53	38.8	05
17	1 1/8-18UNEF	1.40	35.5	0.88	22.3	1.14	28.8	1.65	42.0	06
19	1 1/4-18UNEF	1.52	38.7	0.90	23.0	1.20	30.4	1.78	45.2	07
23	1 7/16-18UNEF	1.72	43.6	0.94	24.0	1.29	32.8	1.97	49.9	38
25	1 9/16-18UNEF	1.86	47.2	0.97	24.6	1.35	34.4	2.09	53.1	09
29	1 7/8-16UN	2.17	55.2	1.02	25.9	1.48	37.6	2.34	59.4	11
33	2 1/16-16UNS	2.38	60.5	1.06	26.9	1.57	39.9	2.53	64.2	13

SHELL SIZE	A THREAD	ØB MAX		C MAX		D MAX		E MAX		MAX ENTRY
		in	mm	in	mm	in	mm	in	mm	
09	M12x1.0	0.74	18.7	0.42	10.6	0.62	15.7	0.84	21.2	32
11	M15x1.0	0.86	21.9	0.44	11.2	0.68	17.2	0.96	24.3	33
13	M18x1.0	1.01	25.6	0.49	12.3	0.76	19.2	1.10	27.9	34
15	M22x1.0	1.13	28.8	0.51	13.0	0.82	20.8	1.23	31.1	35
17	M25x1.0	1.26	32.0	0.55	13.9	0.89	22.6	1.36	34.5	36
19	M28x1.0	1.39	35.2	0.57	14.6	0.95	24.2	1.45	36.9	07
21	M31x1.0	1.51	38.4	0.60	15.3	1.02	25.8	1.58	40.1	08
23	M34x1.0	1.64	41.6	0.63	15.9	1.08	27.4	1.71	43.3	09
25	M37x1.0	1.78	45.2	0.65	16.6	1.14	29.0	1.83	46.5	10

SHELL SIZE	A THREAD	ØB MAX		C MAX		D MAX		E MAX		MAX ENTRY
		in	mm	in	mm	in	mm	in	mm	
08	7/16-28UNEF	0.68	17.3	0.57	14.4	0.72	18.2	1.00	25.5	02
10	9/16-24UNEF	0.80	20.3	0.59	14.9	0.77	19.6	1.12	28.5	03
12	11/16-24UNEF	0.94	23.8	0.62	15.7	0.83	21.0	1.26	32.0	04
14	13/16-20UNEF	1.06	26.8	0.65	16.5	0.92	23.4	1.40	35.5	05
16	15/16-20UNEF	1.17	29.8	0.66	16.8	0.96	24.5	1.52	38.5	06
18	1 1/16-18UNEF	1.31	33.3	0.70	17.8	1.04	26.5	1.65	42.0	07
20	1 3/16-18UNEF	1.43	36.3	0.71	18.1	1.12	28.5	1.79	45.5	08
22	1 5/16-18UNEF	1.57	39.8	0.73	18.5	1.18	30.0	1.91	48.5	09
24	1 7/16-18UNEF	1.69	42.8	0.78	19.7	1.22	31.0	2.03	51.5	10

SHELL SIZE	A THREAD	ØB MAX		C MAX		D MAX		E MAX		MAX ENTRY
		in	mm	in	mm	in	mm	in	mm	
12	5/8-24UNEF	0.80	20.3	0.68	17.3	0.83	21.1	1.16	29.4	03
14	3/4-20UNEF	0.93	23.7	0.70	17.7	0.86	21.9	1.22	31.0	33
16	7/8-20UNEF	1.05	26.7	1.00	25.3	1.20	30.4	1.62	41.2	34
18	1-20UNEF	1.19	30.3	1.01	25.7	1.23	31.2	1.68	42.8	05
20	1 1/8-18UNEF	1.39	35.3	1.04	26.3	1.29	32.8	1.81	46.0	06
22	1 1/4-18UNEF	1.51	38.3	1.06	27.0	1.35	34.4	1.93	49.1	07
24	1 3/8-18UNEF	1.63	41.3	1.09	27.6	1.42	36.0	2.06	52.3	08
28	1 5/8-18UNEF	1.88	47.8	1.13	28.6	1.51	38.4	2.25	57.1	09
32	1 7/8-16UN	2.13	54.2	1.18	29.9	1.64	41.5	2.50	63.4	11
36	2 1/16-16UNS	2.45	62.2	1.22	30.9	1.73	43.9	2.68	68.2	13
40	2 5/16-16UN	2.70	68.6	1.27	32.2	1.85	47.1	2.93	74.5	15

Our comprehensive range of connector accessories boasts a high level of quality along with highly competitive pricing. Available for almost every known type of circular connector, all product is manufactured by Compaero and assembled from our stock to your specifications. This extensive “stock to build” inventory ensures a quick turnaround for all your requirements.

**Visit our website or contact your sales representative today.
Relax... We've got you covered.**



AS85049 TERMINATION BANDS

Compaero can produce and supply a full range of accessories to be used in conjunction with your chosen termination solution. Approved M85049 termination bands, constant force springs and synthetic rubber bushings are all available from stock.



CAPS & PROTECTIVE ACCESSORIES

Compaero's full line of protective accessories provide effective moisture and dust protection for almost every known circular connector. Covers are assembled to order from stock in as little as 48 hours with a wide selection of lanyard types and lengths. Security rings and eyelets of all sizes are also available.



RECTANGULAR BACKSHELLS

Compaero now offer a range of D-Sub & Micro-D rectangular backshells. Available in both solid and split shell variations, with a variety of angles, finishes and termination options on offer.



MOORESVILLE, USA

(+1) 704-235-2900

379 Timber Road,
 Mooresville NC,
 28115 USA

KOCHI, INDIA

(+91) 484 2345 566

No. 38/445, Mother Theresa Road,
 Edappally, Kochi - 682 024,
 Kerala, India

WWW.COMPAERO.COM

All information is believed to be reliable. Readers should independently evaluate the suitability of each product for their application. Compaero makes no warranties as to the accuracy or completeness of the information herein and disclaims any liability regarding its use. Specifications are subject to change without notice. Compaero reserves the right to make changes, without notification to the customer, to processing or materials that do not affect compliance with any applicable specification.