

Series 34 Shorting Caps are for use at the rear of shorting plugs, special test connectors, fiber optic loop-backs and other applications. A variety of lanyard options are available.

- Notes:**
1. All dimensions are in Inches
 2. See Section G for torque information
 3. O-Ring not supplied with 'A' interface (does not affect environmental capability)
 4. Lanyard, if specified, attached with a stainless steel band

PART NUMBER BREAKDOWN

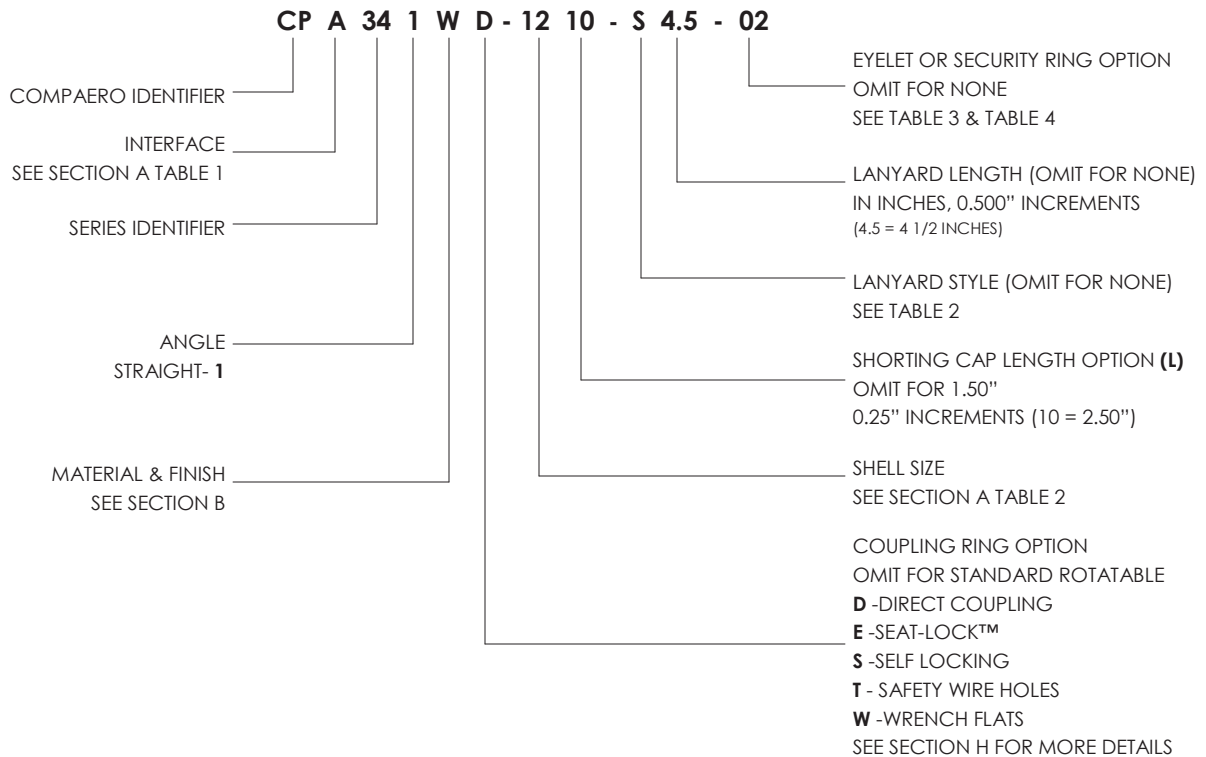

DISCLAIMER: All information is believed to be reliable. Readers should independently evaluate the suitability of each product for their application. Compaero makes no warranties as to the accuracy or completeness of the information herein and disclaims any liability regarding its use. Specifications are subject to change without notice. Compaero reserves the right to make changes, without notification to the customer, to processing or materials that do not affect compliance with any applicable specification. **Drawings are not to scale.**

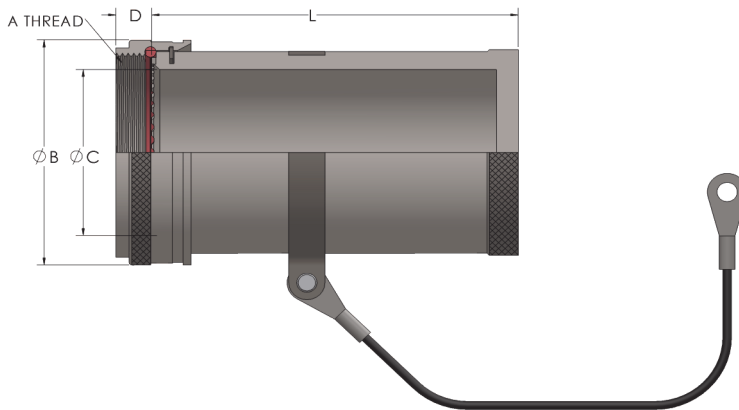

See **Section A** for A Thread, B, C and D Dimensions

LANYARDS



#8 Stainless Steel Sash Chain



Stainless Steel Wire Rope with choice of Jacket Material



Stainless Steel Bead Chain



Nylon Rope, Black

SOLID RING

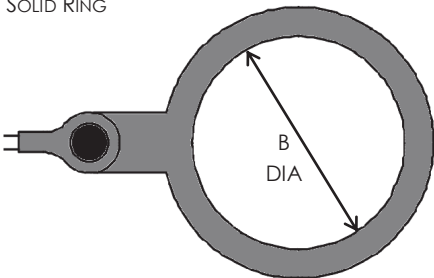

TABLE 2 - LANYARD OPTIONS

ORDERING CODE	DESCRIPTION
X	No Accessory
R	Stainless Steel Wire Rope, PVC Jacket
B	Stainless Steel Bead Chain
S	Stainless Steel Sash Chain
G	Nylon Rope, Black
Y	Stainless Steel Wire Rope, Nylon Jacket
T	Stainless Steel Wire Rope, Teflon Jacket
U	Stainless Steel Wire Rope, Polyurethane Jacket

**TABLE 3
EYELET SPECIFICATIONS**

Dash Number	A DIA
00	No Eyelet
01	0.140 (3.6)
02	0.167 (4.2)
03	0.197 (5.0)
04	0.125 (3.2)
05	0.156 (4.0)
06	0.182 (4.6)
07	0.191 (4.9)
08	0.218 (5.5)

**TABLE 4
SOLID RING SPECIFICATIONS**

Dash Number	B DIA
20	.512 (13.0)
21	.583 (14.8)
22	.709 (18.0)
23	.787 (20.0)
24	.906 (23.0)
25	1.024 (26.0)
26	1.178 (30.0)
27	1.266 (32.2)
28	1.428 (36.3)
29	1.535 (39.0)
30	1.678 (42.6)
31	1.760 (44.7)
32	1.890 (48.0)
33	2.140 (54.4)
34	2.406 (61.1)
35	2.656 (67.5)

EYELET

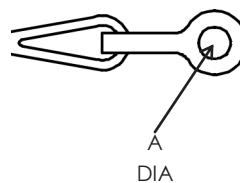

DISCLAIMER: All information is believed to be reliable. Readers should independently evaluate the suitability of each product for their application. Compaero makes no warranties as to the accuracy or completeness of the information herein and disclaims any liability regarding its use. Specifications are subject to change without notice. Compaero reserves the right to make changes, without notification to the customer, to processing or materials that do not affect compliance with any applicable specification. **Drawings are not to scale.**

Compaero manufactures connector accessories for most circular connector series. This section provides information on the more common interfaces. If the desired interface is not shown please contact Compaero. Table 2 contains Threads and dimensions of commonly used connector series. If the required dimensions are not shown please contact Compaero.

TABLE 1 - CONNECTOR INTERFACE SPECIFICATION

Interface Code	Connector Class
A	MIL-DTL-5015 Crimp (MS3400,MS3406; MS3450, MS3456,MS3459) MIL-DTL-26482 Series II (MS3470,MS3476) MIL-DTL-83723 Series I & III
B	MIL-DTL-5015 Solder (MS3100,MS3106) See Table 3
BK	MIL-DTL-83723 Series II
C	MIL-DTL-22992 Left Hand Thread
DK	MIL-DTL-26482 Series I Solder (MS3110, MS3116)
E	MIL-DTL-26500
F	MIL-DTL-38999 Series I & II
G	MIL-DTL-28840
H	MIL-DTL-38999 Series III & IV
J	MIL-DTL-81511 Series 1, 2, 3 & 4
V	ITT VEAM Reverse Bayonet
VA	BS9522, F0017 Patt.105 BS9522, N0001 Patt.603

TABLE 3 - CONNECTOR INTERFACE B

When selecting an accessory with Interface B use the chart below to specify the connector manufacturer being used. If the connector manufacturer is not known please contact Compaero. When generating a part number place the manufacturer letter found below directly after the Interface "B". Shell size of the connector accessory should match the connector shell size.

Example: CPBA491W-1404

The "B" indicates the connector is MIL-DTL-5015 Solder. The "A" indicates the Connector Manufacturer is Amphenol Class A. The "14" indicates the Amphenol Connector is a shell size 14.

Manufacturer Letter	Connector Manufacturer and/or Connector Class
A	Amphenol - Class A (Blue Insert)
B	Bendix - Class A, E & R
C	Cannon - Class A, E & R
R	Amphenol - Class R (Resilient Insert)

DISCLAIMER: All information is believed to be reliable. Readers should independently evaluate the suitability of each product for their application. Compaero makes no warranties as to the accuracy or completeness of the information herein and disclaims any liability regarding its use. Specifications are subject to change without notice. Compaero reserves the right to make changes, without notification to the customer, to processing or materials that do not affect compliance with any applicable specification. **Drawings are not to scale.**



TABLE 2 - CONNECTOR INTERFACE TABLE

INTERFACE (FROM TABLE 1)						DIMENSIONS FROM SERIES SPECIFICATION				
A	D	E	F	G	H	A THREAD	B REF	C REF	D REF (INT)	D REF (INT)
	08	08	08			7/16 - 28 UNEF	0.650	0.269		.188 (F)
					09 (A)	M12 X 1 - 6H	0.770	0.270	.248 (H)	
08						1/2 - 20 UNF	0.650	0.270	.305 (A)	
03	10	10	10			9/16 - 24 UNEF	0.770	0.520	.305 (A)	.188 (F)
					11 (B)	M15 X 1 - 6H	0.820	0.410	.248 (H)	
10						5/8 - 24 UNEF	0.770	0.375	.305 (A)	
	12		12			11/16 - 24 UNEF	0.890	0.645		.188 (F)
					13 (C)	M18 X 1 - 6H	0.940	0.520	.248 (H)	
12		12		11 (A)		3/4 - 20 UNEF	0.940	0.511	.305 (A)	
	14	14	14			13/16 - 20 UNEF	1.020	0.730		.188 (F)
					15 (D)	M22 X 1 - 6H	1.070	0.650	.248 (H)	
14				13 (B)		7/8 - 20 UNEF	1.020	0.585	.305 (A)	
	16	16	16			15/16 - 20 UNEF	1.150	0.855		.188 (F)
					17 (E)	M25 X 1 - 6H	1.210	0.780	.248 (H)	
16				15 (C)		1 - 20 UNEF	1.210	0.710	.305 (A)	
18	18	18	18			1 1/16 - 18 UNEF	1.230	0.789	.305 (A)	.188 (F)
					19 (F)	M28 X 1 - 6H	1.360	0.880	.248 (H)	
					17 (D)	1 1/8 - 18 UNEF	1.360	0.810		
20	20	20	20			1 3/16 - 18 UNEF	1.360	0.914	.305 (A)	.188 (F)
					21 (G)	M31 X 1 - 6H	1.480	1.010	.248 (H)	
					19 (E)	1 1/4 - 18 UNEF	1.530	0.946		
22	22	22	22			1 5/16 - 18 UNEF	1.480	1.039	.305 (A)	.188 (F)
					23 (H)	M34 X 1 - 6H	1.600	1.150	.248 (H)	
24	24	24	24	23 (F)		1 7/16 - 18 UNEF	1.730	1.154	.305 (A)	.188 (F)
					25 (J)	M37 X 1 - 6H	1.700	1.260	.248 (H)	
61						1 1/2 - 18 UNEF	1.670	1.194	.305 (A)	
				25 (G)		1 9/16 - UNEF	1.820	1.222		
28						1 3/4 - 18 UNS	1.970	1.389	.467 (A)	
				29 (H)		1 7/8 - 16 UN	2.190	1.422		
32						2 - 18 UNS	2.220	1.635	.467 (A)	
				33 (J)		2 1/16 - 16 UNS	2.440	1.672		
36						2 1/4 - 16 UN	2.470	1.850	.467 (A)	
40						2 1/2 - 16 UN	2.720	2.065	.467 (A)	
44						2 3/4 - 16 UN		2.320	.467 (A)	
48						3 - 16 UN		2.570	.467 (A)	

DISCLAIMER: All information is believed to be reliable. Readers should independently evaluate the suitability of each product for their application. Compaero makes no warranties as to the accuracy or completeness of the information herein and disclaims any liability regarding its use. Specifications are subject to change without notice. Compaero reserves the right to make changes, without notification to the customer, to processing or materials that do not affect compliance with any applicable specification. **Drawings are not to scale.**

Compaero employs traceable methods when sourcing and using material. All manufacturer certifications are kept on file and are available upon request. For more information please contact Compaero.

Component	Material
Barrels	Aluminum 6061 or 300 Series Stainless Steel
Barrel Castings	Aluminum Alloy A380
Braid / Shield	Tinned Copper per QQB-575
Clamp Bodies	Aluminum 6061 or 300 Series Stainless Steel
Clamp Grommets, Bushings	Neoprene, Silicone or Fluorosilicone
Clamp Nuts	300 Series Stainless Steel
Clamp Saddles	Aluminum 6061 or 300 Series Stainless Steel
Clamp Hardware	300 Series Stainless Steel
Coupling Rings	Aluminum 6061 or 300 Series Stainless Steel
E-Nuts	Aluminum 6061 or 300 Series Stainless Steel
Ferrules	Aluminum 6061 or 300 Series Stainless Steel
Followers	Aluminum 6061 or 300 Series Stainless Steel
O-Rings	Silicone
Retaining Rings	300 Series Stainless Steel
Self Locking Clips	Non Corrosive material

DISCLAIMER: All information is believed to be reliable. Readers should independently evaluate the suitability of each product for their application. Compaero makes no warranties as to the accuracy or completeness of the information herein and disclaims any liability regarding its use. Specifications are subject to change without notice. Compaero reserves the right to make changes, without notification to the customer, to processing or materials that do not affect compliance with any applicable specification. **Drawings are not to scale.**

Table 1 shows common Compaero finishes and their Mil-Spec equivalents (where applicable).
Additional finishes are available upon request.

TABLE 1 - Common Material and Finish Codes

Compaero Ordering Code	AS85049	Material	Finish
C	A	Aluminum	Black anodize - In accordance with Class 2 of AMS-A-8625, Type II. -65 to +175 °C
F	N	Aluminum	Electroless nickel - In accordance with AMS-C-26074 or AMS2404. -65 to +200 °C
H	N/A	Aluminum	Clear Cadmium - SAE-AMS-QQ-P-416 Type II Class 2 over electroless nickel, 1000 Hour Salt Spray, Conductive -65 to +175°C
W	W	Aluminum	Cadmium, Olive drab over suitable underplate, 1000 hour salt spray -65 to +175 °C
P	X	Aluminum	Nickel fluorocarbon polymer. Nickel with fluorocarbon polymer additives over a suitable underplate to withstand
D	Y	Aluminum	Pure dense electrodeposited aluminum in accordance with MIL-DTL-83488, Type II, to withstand 500 hours of salt
T	Z	Aluminum	Zinc nickel, Black, in accordance with ASTM B841 over suitable underplate to withstand 1000 hours of salt spray testing.
Y	N/A	Aluminum	Zinc-Cobalt, Olive Drab, ASTM B 840 Grade 6 Type D over electroless nickel, 350 Hour Salt Spray, Conductive -65 to +175°C
Z	N/A	Aluminum	Zinc-Cobalt, Black, ASTM B 840 Grade 6 Type D over electroless nickel 350 Hour Salt Spray, Conductive -65 to +175°C
KB	B	Stainless Steel	Black cadmium - In accordance with AMS-QQ-P-416, Type II, Class 3. -65 to +175 °C
K	S	Stainless Steel	Passivate - In accordance with AMS-QQ-P-35, AMS 2700, or ASTM A 967. -65 to + 200 °C
KP	XS	Stainless Steel	Nickel fluorocarbon polymer. Nickel with fluorocarbon polymer additives over a suitable underplate to withstand
KD	YS	Stainless Steel	Pure dense electrodeposited aluminum in accordance with MIL-DTL-83488, Type II
KT	ZS	Stainless Steel	Zinc nickel in accordance with ASTM B841 over suitable underplate to withstand 1000 hours of salt spray testing
KN	N/A	Stainless Steel	Electrodeposited Nickel per SAE-AMS-QQ-N-290 Class 1 Grade F
M	T	Composite	Composite material without plating
MJ	J	Composite	Olive drab cadmium plate in accordance with AMS-QQ-P-416. To withstand 2000 hour salt spray. Finish shall be electrically conductive. -65 to + 175 °C
ML	L	Composite	Cadmium (olive drab) over electroless nickel, selective plating -65 to +175 °C
MM	M	Composite	Electrically conductive electroless nickel plating. Finish shall withstand 2000 hour salt spray. -65 to +200 °C

DISCLAIMER: All information is believed to be reliable. Readers should independently evaluate the suitability of each product for their application. Compaero makes no warranties as to the accuracy or completeness of the information herein and disclaims any liability regarding its use. Specifications are subject to change without notice. Compaero reserves the right to make changes, without notification to the customer, to processing or materials that do not affect compliance with any applicable specification. **Drawings are not to scale.**



Shell Size	Connector Accessories onto Connector Threads Torque Values are in Inch-Pounds			
	MIL-DTL-5015 (MS3100) MIL-DTL-26500 MIL-DTL-81511	MIL-DTL-26482 S1 MIL-DTL-38999 S1 & S2	MIL-DTL-5015 (MS3400) MIL-DTL-26482 S2 MIL-DTL-28840	MIL-DTL-38999 S3 & S4 MIL-DTL-83723 MIL-DTL-22992
08, 09	30 - 40	30 - 40	51 - 61	51 - 61
10, 11	30 - 40	30 - 40	71 - 81	71 - 81
12, 13	35 - 45	35 - 45	103 - 113	103 - 113
14, 15	35 - 45	35 - 45	111 - 121	111 - 121
16, 17	35 - 45	35 - 45	111 - 121	111 - 121
18, 19	35 - 45	35 - 45	111 - 121	111 - 121
20, 21	75 - 85	75 - 85	131 - 141	131 - 141
22, 23	75 - 85	75 - 85	131 - 141	131 - 141
24, 25	75 - 85	75 - 85	131 - 141	131 - 141
28	115 - 125	115 - 125	143 - 153	143 - 153
32	115 - 125	115 - 125	143 - 153	143 - 153
36	115 - 125	115 - 125	143 - 153	143 - 153
40	155 - 165	155 - 165	159 - 169	159 - 169
44	155 - 165	155 - 165	159 - 169	159 - 169
48	155 - 165	155 - 165	159 - 169	159 - 169

Cable Clamps onto Backshells Torque Values are in Inch-Pounds	
Clamp Entry Size	Torque Value in Inch-Pounds
01	35 - 40
02	35 - 40
03	35 - 55
04	35 - 55
05	35 - 55
06	40 - 60
07	40 - 60
08	40 - 60
09	80 - 100
10	80 - 100
11	80 - 100
12	80 - 100

Cable Clamp Hardware (Screws)	
Thread	Torque Value in Inch-Pounds
2-56	1.5 - 2.5
4-40	3.5 - 4.5
6-32	5.0 - 7.0
8-32	7.0 - 9.0
10-32	9.0 - 11.0
1/4 - 20	11.0 - 13.0

DISCLAIMER: All information is believed to be reliable. Readers should independently evaluate the suitability of each product for their application. Compaero makes no warranties as to the accuracy or completeness of the information herein and disclaims any liability regarding its use. Specifications are subject to change without notice. Compaero reserves the right to make changes, without notification to the customer, to processing or materials that do not affect compliance with any applicable specification. **Drawings are not to scale.**

Style 2 Coupling Rings

When the specified cable entry exceeds dimension C on the connector interface side, Style 2 will be used. Style 2 adapters will maintain environmental sealing and EMI/RFI shielding (if specified in the series). The specified overall length on a Style 2 adapter will be increased by 1.25" maximum, however, will be kept as minimal as possible. To specify a one piece adapter (Style 1 when Style 2 should be used) place a modification code -014 at the end of the part number when ordering.

Modification Code Example: CPA461W-1410-VG0-014

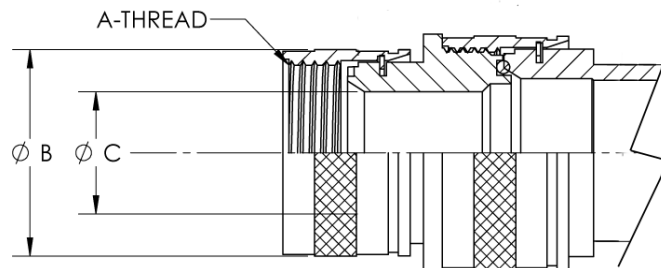

Direct Coupling Rings (Option D)

Direct coupling rings can be specified on most Compaero adapters and backshells. Below is a diagram of a direct coupling ring when called out on a straight adapter or backshell. When specifying direct coupling on 45 and 90 degree parts a screw in adapter will be supplied.

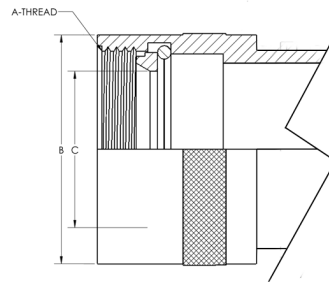

Safety Wire Holes (Option T)

Safety wire holes can be specified on standard rotatable coupling rings to use with safety wire after installation. Safety wire ensures the coupling ring will not un-couple during shock and/or vibration. These are common on AS85049 accessories. When this option is specified the coupling ring will have 3 equally spaced wire holes (120 degrees apart). Safety Wire Holes are sufficient to accommodate 0.020 inch wire.

Wrench Flat Coupling Rings (Option W)

Common on most TACOM adapters, wrench flats are an available option on most Compaero adapters and backshells. Wrench flats allow for an easier way of screwing on the coupling ring (with a wrench) when working in tight spaces. For specifications on specific wrench flat dimensions (based on shell size and connector series) please contact Compaero.

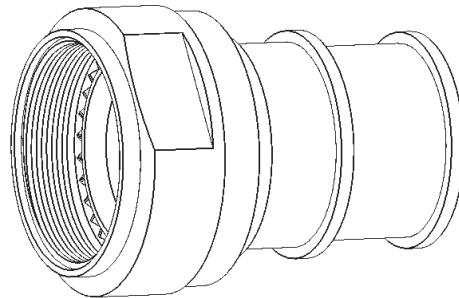

Self-Locking Coupling Rings, Detent (Option S)

Detent style self locking feature a ratcheting coupling ring using non corrosive clips located within the coupling ring. Many AS85049 specifications specify this detent style self locking coupling ring making this one of the most popular ways of achieving a self locking adapter or backshell.

Seat-Lock™ Coupling Rings, Non-Detent Self-Locking (Option E)

Using a spring loaded retaining ring, Compaero Seat-Lock™ coupling rings are a non detent way to achieve self locking. This option also ensures that the accessory teeth of the connector mate properly with the teeth on the adapter or backshell by applying constant force between the two. The Compaero Seat-Lock™ option is an excellent choice if an easy, economical self locking solution is required.



How To Order:

CPA461WD-1203-B1-VG0-8

- COUPLING RING OPTION
- OMIT FOR STANDARD ROTATABLE
- D** -DIRECT COUPLING
- E** -SEAT-LOCK™
- S** -SELF LOCKING
- T** - SAFETY WIRE HOLES
- W** -WRENCH FLATS

DISCLAIMER: All information is believed to be reliable. Readers should independently evaluate the suitability of each product for their application. Compaero makes no warranties as to the accuracy or completeness of the information herein and disclaims any liability regarding its use. Specifications are subject to change without notice. Compaero reserves the right to make changes, without notification to the customer, to processing or materials that do not affect compliance with any applicable specification. Drawings are not to scale.